



Request to Authorize Additional Funds Cole Park Pier Improvements



Corpus Christi B Corporation
January 11, 2021

Cole Park Pier

- Cole Park has had a fishing pier since the 1930's.
- The current reinforced concrete Cole Park Pier was constructed in 1971.
- The pier's condition has been deteriorating rapidly for several years.
- Funding was added to Bond 2018 for the Cole Park and Dimitt Fishing Piers.
- Access to the pier had been restricted and the first span of the pier collapsed in early 2018.



Cole Park Pier

- It was understood that the Bond funding was not adequate to complete both projects.
- Staff has been seeking supplemental funding to complete both pier projects.
- Type B has previously pledged \$4.2M.
- No external source of grant funding has been identified.



Cole Park Pier Design Features

Public input was sought on features that users desired. The following features were included in the design based on public input:

- A wider walkway;
- shade structures;
- an observation area with seating;
- a large plaza area for events;
- more parking;
- new walkways connecting parking lots to plaza;
- electrical improvements & better lighting;
- at least 500 feet long (like the current pier).



Current Situation

- The design was completed, and project bid in November 2018.
 - The City received 3 bids on December 9, 2020.
 - The lowest responsive bid was submitted by JM Davidson, Ltd of Aransas Pass, TX in the amount of \$7,542,527.00.
 - The lowest bid exceeds currently available funds.
 - Council awarded the construction contract to the lowest bidder, JM Davidson.
 - This required temporarily borrowing funds from Unreserved Fund Balance in order to certify funds. Those funds are expected to be returned.
 - Staff is seeking to fill the funding gap so that the entire scope of work can be completed.
-



Next Steps



- If additional funding cannot be identified, approximately \$2.2M in project scope will need to be delayed.
 - This would delay most of the architectural features and land side improvements such as the parking lot and plaza.
 - Staff is requesting that Type B increase their financial commitment by \$797,625 to a total of \$5M.
 - Staff will seek to fund the remainder of the shortfall from other sources.
-



Questions



?

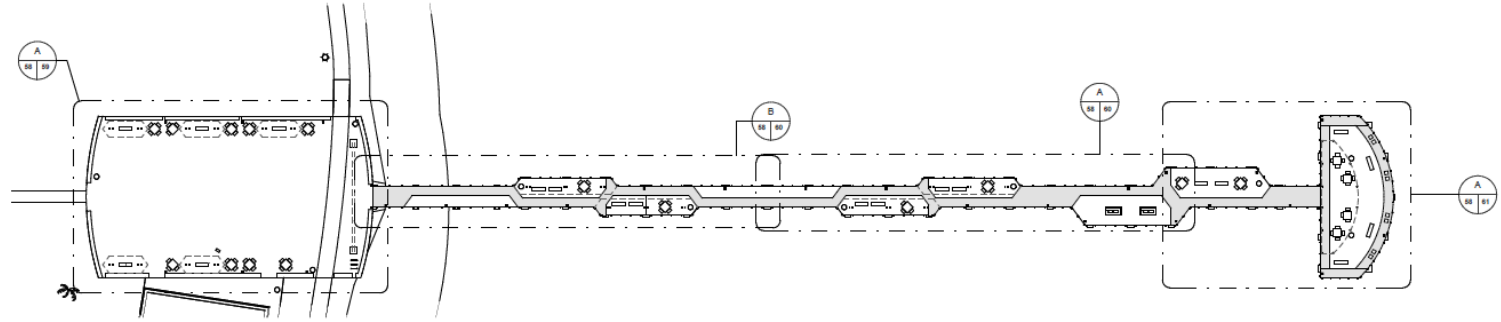

A OVERALL FURNITURE AND AMENITY PLAN
 1"=30'-0"

