

WASTEWATER COLLECTION LINE EXTENSION CONSTRUCTION AND REIMBURSEMENT AGREEMENT

This Wastewater Collection Line Extension and Reimbursement Agreement ("Agreement") is entered into between the City of Corpus Christi ("City"), a Texas home-rule municipality, and **Devonshire Custom Homes, Inc.**, ("Developer/Owner"), a **Texas Corporation**.

WHEREAS, the Developer/Owner, in compliance with the City's Unified Development Code ("UDC"), has a plat, approved by the Planning Commission on **November 13, 2019** to develop a tract of land, to wit approximately **10.734** acres known as **Westwood Heights Unit 4. Located on Sunny Dr., south of Leopard St.** as shown in the attached **Exhibit 1**, the content of such exhibit being incorporated by reference into this Agreement;

WHEREAS, under the UDC, the Developer/Owner is responsible for construction of the Wastewater Collection Line Extension ("Wastewater Improvements");

WHEREAS, under the UDC, the Developer/Owner is eligible for reimbursement of the Developer/Owner's costs for the construction of Wastewater Improvements;

WHEREAS, it is to the best interest of the City that the Wastewater Improvements be constructed to its ultimate capacity under the City's applicable Master Plan;

WHEREAS, Section 8.5.2.E. of the UDC authorizes the acceptance of applications to be eligible for reimbursement in the future when funds become fully available in the Wastewater Collection Line Trust Fund and are appropriated by the City Council;

WHEREAS, the Developer/Owner has submitted an application for reimbursement of the costs from the Wastewater Collection Line Trust Fund for installing the Wastewater Improvements, as shown in **Exhibit 2**, the content of such exhibit being incorporated by reference into this Agreement;

WHEREAS, the Wastewater Collection Line Trust Fund does not currently have sufficient funds to fully reimburse Developer/Owner for Wastewater Improvements; and

WHEREAS, Developer/Owner may be paid when assets of the Wastewater Collection Line Trust Fund are sufficient, authorized for such purpose, and Developer/Owner has priority per UDC §8.5.2. E.

NOW, THEREFORE, in consideration of the mutual promises and covenants contained in this Agreement, the parties do covenant and agree as follows:

1. TRUSTEE LIABILITY.

- a. The City is executing this agreement as trustee of the Wastewater Trust Fund pursuant to UDC §8.5. The City is acting as trustee to further its governmental functions of providing water and sewer service. Texas Constitution Article 11, Section 3 prohibits the City from becoming a subscriber to the capital of any private corporation or association, or make any appropriation or donation to the same, or in anywise loan its credit. As such, the City's participation as Trustee does not create a loan of its credit. Execution of this agreement constitutes a promise to pay only to the

extent that the assets and future assets of the trust are sufficient for such purpose and it is expressly agreed that any judgment will only be satisfied out of the assets of the trust and not out of the City's assets. The City is excluded from personal liability.

- b. The Wastewater Collection Line Trust Fund was established by Ordinance No. 17396 to encouraging the orderly development of subdivisions within and surrounding the City of Corpus Christi, Texas and continues pursuant Texas Local Government Code §395.001(4)(C). The revenue generated for funding and continuation of the Wastewater Collection Line Trust Fund is subject to legislation of the State of Texas and the City of Corpus Christi. Nothing in this agreement guarantees neither the continuation nor future revenues of the Wastewater Collection Line Trust Fund. The City is not liable for modification or termination of the Wastewater Collection Line Trust Fund. The Developer/Owner agrees that any modification or termination of the Wastewater Collection Line Trust Fund is a legislative action and does not constitute a breach of trust, an act of bad faith, an intentional or reckless indifference to the interest of a beneficiary, or a profit derived by the trustee from a breach of trust.

2. PLANS AND SPECIFICATIONS.

- a. Developer/Owner shall contract with a professional engineer licensed in the State of Texas and acceptable to the City's Development Services Engineer to prepare plans and specifications for the Wastewater Improvements, as shown in the attached **Exhibit 3**, the content of such exhibit being incorporated by reference into this Agreement, with the following minimum requirements:

Project Details					
Line Item	Description	Quantity	Unit	Unit Price	Total Contract Value
1	8" PVC PIPE	162	LF	\$ 110.00	\$ 17,820.00
2	PAVEMENT PATCHING	1	EA	\$ 8,500.00	\$ 8,500.00
				Subtotal:	\$ 26,320.00
				Engineering, Surveying, and Testing (@ 10%):	\$ 2,632.00
				Total Contract Value:	\$ 28,952.00
				Reimbursement Amount on Off-Site (50%)	\$ 14,476.00
				Credits:	
				Total Reimbursable Amount:	\$ 14,476.00

- b. The plan must be in compliance with the City's master plans.
- c. The plans and specifications must comply with the City's Wastewater Standards Detail Sheets and Standard Specifications.
- d. Before the Developer/Owner starts construction, the plans and specifications must be approved by the City's Development Services Engineer.

3. REIMBURSEMENT.

- a. The cost for the Wastewater Improvements is **\$14,476.00**. Subject to the conditions for reimbursement from the Wastewater Collection Line Trust Fund and the appropriation of funds, the City will reimburse the developer, the reasonable actual cost of the Wastewater Improvements up to an amount not to exceed **\$14,476.00** as shown in the attached Exhibit 4, the contents of such exhibit being incorporated by reference into this Agreement.
- b. Subject to the conditions for reimbursement from the Wastewater Collection Line Trust Fund per the UDC and this agreement, the City agrees to reimburse the Developer/Owner on a monthly basis upon invoicing for work performed. The submitted invoice shall be deemed administratively complete by the City prior to payment. The reimbursement will be made no later than 30 days from the date of the City's administrative approval of the invoice. Developer/Owner shall submit all required performance bonds and proof of required insurance under the provisions of this Agreement.
- c. Cost-supporting documentation to be submitted shall include:
 - 1. Summary of Costs and Work Performed on Form provided by the Development Services Department.
 - 2. Contractor and professional services invoices detailing work performed.
 - 3. The first reimbursement request requires submittal of invoices for work performed. Future disbursements shall provide evidence of payment by the developer/owner through a cancelled check or bank ACH for the previous submittal. The final reimbursement request shall require evidence that all invoices to date have been paid.
- d. To be eligible for reimbursement, the work must be constructed in a good and workmanlike manner and must have been inspected and accepted by the City. The City agrees to conduct periodic inspections and approve the progress of the work at key points during construction.
- e. The final 5% of the total contract reimbursement amount will be held as retainage until such time the City issues acceptance of public infrastructure in accordance with Unified Development Code.
- f. In the event that this Agreement is terminated by the City as a result of an uncured default by the Developer/Owner and at a time when there has been a partial completion and/or partial payment for the improvements, then the City shall only

reimburse the Developer/Owner for its costs that were legitimately incurred towards the completion of the improvements that have been inspected and accepted by the City up to the time that the uncured default occurred.

4. PAYMENTS, CREDITS, AND DEFERRED REIMBURSEMENT.

- a. All payments, credits, priority of reimbursement, and deferred reimbursement shall be made in accordance with UDC §8.5. Developer/Owner understands and agrees that if funds are not available in the Wastewater Collection Line Trust Fund, that reimbursement will not be made until such funds are available, appropriated, and Developer/Owner has priority per UDC §8.5.2. Pursuant UDC §8.5.2. E., priority is determined according to the date the reimbursement agreement is approved by the City Council.
- b. Payments will not be paid when funds are not available in the Wastewater Collection Line Trust Fund. Payments may be made when monies are available in and appropriated from the Wastewater Collection Line Trust Fund and the Developer/Owner has priority in accordance with UDC §8.5.2. E.
- c. If the developer is owed funds from the Wastewater Collection Line Trust Fund, the developer will be given credit for lot or acreage fees that are due on subsequent final plats filed with the County Clerk in accordance with UDC §8.5.2. E. The amounts credited will be deducted from the outstanding amounts owed to the developer by the Wastewater Collection Line Trust Fund until the total amount owed has been paid, provided that the lands being platted are within or contiguous to the boundaries of the preliminary plat of the originally developed property, the land will be served by the wastewater collection line for which the credit was given, and an extension of the collection line was not required to serve the land.

5. DEVELOPER/OWNER TO COMPLETE IMPROVEMENTS. Developer/Owner shall award a contract and complete the Wastewater Improvements under the approved plans and specifications within **24** months from the date of City Council approval of this agreement.

6. NOTICES.

a. Any notice or other communication required or permitted to be given under this Agreement must be given to the other party in writing at the following address:

- 1. If to the Developer/Owner:

**Devonshire Custom Homes, Inc
Navid Zarghooni
2129 Airline Rd
Corpus Christi, Texas 78414**

- 2. If to the City:

City of Corpus Christi
Attn: Director, Development Services Department
2406 Leopard Street 78401
P. O. Box 9277

Corpus Christi, Texas 78469-9277

with a copy to:

City of Corpus Christi
Attn: Assistant City Manager, Business Support Services
1201 Leopard Street 78401
P. O. Box 9277
Corpus Christi, Texas 78469-9277

b. Notice must be made by United States Postal Service, First Class mail, certified, return receipt requested, postage prepaid; by a commercial delivery service that provides proof of delivery, delivery prepaid; or by personal delivery.

c. Either party may change the address for notices by giving notice of the change under the provisions of this section.

7. REQUIRED CONSTRUCTION. Developer/Owner shall construct the Wastewater Improvements in compliance with the City's UDC, the City's Infrastructure Design Manual, and all local, state and federal laws, codes and regulations, in accordance with the plans and specifications submitted to the City's Development Services Department and reviewed and approved by the City's Development Services Engineer.

8. SITE IMPROVEMENTS. Prior to the start of construction of the Wastewater Improvements, Developer/Owner shall acquire and dedicate to the City the required additional public utility easements ("Easements"), if any, necessary for the completion of the Wastewater Improvements. If any of the property needed for the Easements is owned by a third party and the Developer/Owner is unable to acquire the Easements through reasonable efforts, then the City may use its powers of eminent domain to acquire the Easements. Developer will be responsible for cost of acquisition, payable from the reimbursement agreed to in this agreement.

9. PLATTING FEES. Developer/Owner shall pay to the City the required acreage fees and pro-rata fees as required by the UDC.

10. TIME IS OF THE ESSENCE. Time is of the essence in the performance of this contract.

11. PROMPT AND GOOD FAITH ACTIONS. The parties shall act promptly and in good faith in performing their duties and obligations under this Agreement. If this Agreement calls for review or inspections by the City, then the City's reviews or inspections must be completed thoroughly and promptly.

12. DEFAULT. The following events shall constitute default:

a. Developer/Owner fails to engage a professional engineer for the preparation of plans and specifications by the 10th calendar day after the date of approval of this Agreement by the City Council.

b. Developer/Owner's professional engineer fails to submit the plans and specifications to the City's Director of Engineering Services by the 40th calendar day after the date of approval by City Council.

- c. Developer/Owner fails to award a contract for the construction of the project, according to the approved plans and specifications, by the 70th calendar day after the date of approval by City Council.
- d. Developer/Owner's contractor does not reasonably pursue construction of the Wastewater Improvements under the approved plans and specifications.
- e. Developer/Owner's contractor fails to complete construction of the Wastewater Improvements, under the approved plans and specifications as provided in section 4 of this agreement.
- f. Either the City or the Developer/Owner otherwise fails to comply with its duties or obligations under this Agreement.

13. NOTICE AND CURE.

- a. In the event of a default by either party under this Agreement, the non-defaulting party shall deliver notice of the default, in writing, to the defaulting party stating, in sufficient detail, the nature of the default and the requirements to cure such default.
- b. After delivery of the default notice, the defaulting party has 15 business days from the delivery of the default notice ("Cure Period") to cure the default.
- c. In the event the default is not cured by the defaulting party within the Cure Period, then the non-defaulting party may pursue its remedies in this section.
- d. Should Developer/Owner fail to perform any obligation or duty of this Agreement, the City shall give notice to Developer/Owner, at the address stated in section 5, of the need to perform the obligation or duty, and should Developer/Owner fail to perform the required obligation or duty within 15 days of receipt of the notice, the City may perform the obligation or duty, charging the cost of such performance to Developer/Owner by reducing the reimbursement amount due Developer/Owner.
- e. In the event of an uncured default by the Developer/Owner, after the appropriate notice and Cure Period, the City has all its common law remedies and the City may:
 - 1. Terminate this Agreement after the required notice and opportunity to cure the default;
 - 2. Refuse to record a related plat or issue any certificate of occupancy for any structure to be served by the project; and/or
 - 3. Perform any obligation or duty of the Developer/Owner under this Agreement and charge the cost of such performance to the Developer/Owner. The Developer/Owner shall pay to the City the reasonable and necessary cost of the performance within 30 days from the date the Developer/Owner receives notice of the cost of performance. In the event the Developer/Owner pays the City under the preceding sentence and is not otherwise in default under this Agreement, then the Agreement shall be considered in effect and no longer in default.

f. In the event of an uncured default by the City after the appropriate notice and Cure Period, the Developer/Owner has all its remedies at law or in equity for such default.

14. FORCE MAJEURE.

a. The term "force majeure" as employed in this Agreement means and refers to acts of God; strikes, lockouts, or other industrial disturbances; acts of public enemies; insurrections; riots; epidemics; landslides; lightning; earthquakes; fires; hurricanes; storms; floods; washouts; droughts; arrests; civil disturbances; explosions; or other causes not reasonably within the control of the party claiming the inability.

b. If, by reason of force majeure, either party is rendered wholly or partially unable to carry out its obligations under this Agreement, then the party claiming force majeure shall give written notice of the full particulars of the force majeure to the other party within ten (10) business days after the occurrence or waive the right to claim it as a justifiable reason for delay. The obligations of the party giving the required notice, to the extent affected by the force majeure, are suspended during the continuance of the inability claimed but for no longer period, and the party shall endeavor to remove or overcome such inability with all reasonable dispatch.

15. THIRD-PARTY BENEFICIARY. Developer/Owner's contracts with the professional engineer for the preparation of the plans and specifications for the construction of the Wastewater Improvements, contracts for testing services, and contracts with the contractor for the construction of the Wastewater Improvements must provide that the City is a third-party beneficiary of each contract.

16. PERFORMANCE AND PAYMENT BONDS. Developer/Owner shall, before beginning the work that is the subject of this Agreement, furnish a performance bond payable to the City of Corpus Christi if the contract is in excess of \$100,000 and a payment bond if the contract is in excess of \$50,000. Bonds furnished must meet the requirements of Texas Insurance Code 3503, Texas Government Code 2253, and all other applicable laws and regulations. The performance or payment bond must name the City as an obligee. If the Developer/Owner is not an obligor, then Developer/Owner shall be named as a joint obligee. The bond must clearly and prominently display on the bond or on an attachment to the bond:

(1) the name, mailing address, physical address, and telephone number, including the area code, of the surety company to which any notice of claim should be sent; or

(2) the toll-free telephone number maintained by the Texas Department of Insurance under Subchapter B, Chapter 521, Insurance Code, and a statement that the address of the surety company to which any notice of claim should be sent may be obtained from the Texas Department of Insurance by calling the toll-free telephone number.

17. DEDICATION OF WASTEWATER IMPROVEMENTS. Upon completion of the construction, dedication of Wastewater Improvements will be subject to City inspection and approval.

18. WARRANTY. Developer/Owner shall fully warranty the workmanship of and function of the Wastewater Improvements and the construction thereof for a period of one year from and after the date of acceptance of the facilities by the City's Director of Engineering Services.

19. INDEMNIFICATION. Developer/Owner covenants to fully indemnify, save and hold harmless the City of Corpus Christi, its officers, employees, and agents, ("indemnitees") against any and all liability, damage, loss, claims, demands suits and causes of action of any nature whatsoever asserted against or recovered from city on account of injury or damage to person including, without limitation on the foregoing, workers compensation and death claims, or property loss or damage of any other kind whatsoever, to the extent any injury, damage, or loss may be incident to, arise out of, be caused by, or be in any way connected with, either proximately or remotely, wholly or in part, the Developer/Owner's failure to comply with its obligations under this agreement or to provide city wastewater service to the development, including injury, loss, or damage which arise out of or are in any manner connected with, or are claimed to arise out of or be in any manner connected with the construction, installation, existence, operation, use, maintenance, repair, restoration, or removal of the public improvements associated with the development described above, including the injury, loss or damage caused by the sole or contributory negligence of the indemnitees or any of them, regardless of whether the injury, damage, loss, violation, exercise of rights, act, or omission is caused or is claimed to be caused by the contributing or concurrent negligence of indemnitees, or any of them, but not if caused by the sole negligence of indemnitees, or any of them, unmixed with the fault of any other person or entity, and including all expenses of litigation, court costs, and attorneys fees, which arise, or are claimed to arise, out of or in connection with the asserted or recovered incident.

This indemnity specifically includes all claims, damages, and liabilities of whatever nature, foreseen or unforeseen, under any hazardous substance laws, including but not limited to the following:

(a) all fees incurred in defending any action or proceeding brought by a public or private entity and arising from the presence, containment, use, manufacture, handling, creating, storage, treatment, discharge, release or burial on the property or the transportation to or from the property of any hazardous substance. The fees for which the developer/owner shall be responsible under this subparagraph shall include but shall not be limited to the

fees charged by (i) attorneys, (ii) environmental consultants, (iii) engineers, (iv) surveyors, and (v) expert witnesses.

(b) any costs incurred attributable to (i) the breach of any warranty or representation made by Developer/Owner in this agreement, or (ii) any cleanup, detoxification, remediation, or other type of response action taken with respect to any hazardous substance on or under the property regardless of whether or not that action was mandated by the federal, state or local government.

This indemnity shall survive the expiration or earlier termination of the agreement.

20. ASSIGNMENT OF AGREEMENT. This Agreement or any rights under this Agreement may not be assigned by the Developer/Owner to another without the written approval and consent of the City's City Manager.

21. DISCLOSURE OF INTEREST. Developer/Owner agrees, in compliance with the Corpus Christi Code of Ordinance Sec. 2-349, to complete, as part of this Agreement, the Disclosure of Interest form attached to this Agreement as **Exhibit 5**.

22. CERTIFICATE OF INTERESTED PARTIES. Developer/Owner agrees to comply with Texas Government Code section 2252.908 and complete Form 1295 Certificate of Interested Parties as part of this agreement. Form 1295 requires disclosure of "interested parties" with respect to entities that enter contracts with cities. These interested parties include:

- (1) persons with a "controlling interest" in the entity, which includes:
 - a. an ownership interest or participating interest in a business entity by virtue of units, percentage, shares, stock or otherwise that exceeds 10 percent;
 - b. membership on the board of directors or other governing body of a business entity of which the board or other governing body is composed of not more than 10 members; or
 - c. service as an officer of a business entity that has four or fewer officers, or service as one of the four officers most highly compensated by a business entity that has more than four officers.
- (2) a person who actively participates in facilitating a contract or negotiating the terms of a contract with a governmental entity or state agency, including a broker, intermediary, adviser or attorney for the business entity.

Form 1295 must be electronically filed with the Texas Ethics Commission at https://www.ethics.state.tx.us/whatsnew/elf_info_form1295.htm. The form must then be printed, signed, notarized and filed with the City. For more information, please review the Texas Ethics Commission Rules at <https://www.ethics.state.tx.us/legal/ch46.html>.

23. CONFLICT OF INTEREST. Developer/Owner agrees to comply with Chapter 176 of the Texas Local Government Code and file Form CIQ with the City Secretary's Office, if required. For more information and to determine if you need to file a Form CIQ, please review the

information on the City Secretary's website at <http://www.cctexas.com/government/city-secretary/conflict-disclosure/index>.

24. AUTHORITY. All signatories signing this Agreement warrant and guarantee that they have the authority to act on behalf of the entity represented and make this Agreement binding and enforceable by their signature.

25. EFFECTIVE DATE. This Agreement becomes effective and is binding upon and inures to the benefit of the City and the Developer/Owner and their respective heirs, successors, and assigns from and after the date of final execution by all parties.

Remainder of page intentionally left blank; signature page to follow.

EXECUTED IN ONE ORIGINAL this _____ day of _____, 20____.

ATTEST:

CITY OF CORPUS CHRISTI

Rebecca Huerta
City Secretary

Albert J. Raymond III, AIA, CBO
Director of Development Services

APPROVED AS TO LEGAL FORM:

Buck Brice (Date)
Deputy City Attorney
For City Attorney

DEVELOPER/OWNER:

**Devonshire Custom Homes, Inc.
2129 Airline Rd.
Corpus Christi, Texas 78414**

By: _____
**Navid Zarghooni
President**

**STATE OF TEXAS §
 §
COUNTY OF _____ §**

This instrument was acknowledged before me on _____, 20____, by **Navid Zarghooni, President of Devonshire Custom Homes, Inc. a Texas Corporation**, on behalf of said company.

Notary Public's Signature

EXHIBIT 1

STATE OF TEXAS §
COUNTY OF NUECES §

WE, DEVONSHIRE CUSTOM HOMES, INC., HEREBY CERTIFY THAT WE ARE THE OWNERS OF THE LAND EMBRACED WITHIN THE BOUNDARIES OF THE FOREGOING PLAT, SUBJECT TO A LIEN IN FAVOR OF _____ THAT WE HAVE HAD SAID LAND SURVEYED AND SUBDIVIDED AS SHOWN, THAT STREETS AND EASEMENTS AS SHOWN HAVE BEEN HERETOFORE DEDICATED, OR IF NOT PREVIOUSLY DEDICATED, ARE HEREBY DEDICATED TO THE PUBLIC USE FOREVER AND THAT THIS PLAT WAS MADE FOR THE PURPOSES OF DESCRIPTION AND DEDICATION.

THIS THE _____ DAY OF _____, 20____,

NAVID ZARGHOONI, PRESIDENT

STATE OF TEXAS §
COUNTY OF NUECES §

THIS INSTRUMENT WAS ACKNOWLEDGED BEFORE ME BY NAVID ZARGHOONI, PRESIDENT OF DEVONSHIRE CUSTOM HOMES, INC.

THIS THE _____ DAY OF _____, 20____,

NOTARY PUBLIC, IN AND FOR THE STATE OF TEXAS

STATE OF TEXAS §
COUNTY OF NUECES §

I, NIXON M. WELSH, REGISTERED PROFESSIONAL LAND SURVEYOR OF BASS & WELSH ENGINEERING, HEREBY CERTIFY THAT THE FOREGOING PLAT WAS PREPARED FROM A SURVEY MADE ON THE GROUND UNDER MY DIRECTION, IS TRUE AND CORRECT AND THAT WE HAVE BEEN ENGAGED TO SET ALL LOT CORNERS UPON COMPLETION OF SUBDIVISION CONSTRUCTION IMPROVEMENTS WITHOUT DELAY.

THIS THE _____ DAY OF _____, 20____,

NIXON M. WELSH, R. P. L. S.

STATE OF TEXAS §
COUNTY OF NUECES §

WE, _____ (NAME), HEREBY CERTIFY THAT WE ARE THE HOLDERS OF A LIEN ON THE LAND EMBRACED WITHIN THE BOUNDARIES OF THE FOREGOING MAP AND THAT WE APPROVE THE SUBDIVISION AND DEDICATION FOR THE PURPOSES AND CONSIDERATIONS THEREIN EXPRESSED.

BY: _____

TITLE: _____

STATE OF TEXAS §
COUNTY OF NUECES §

THIS INSTRUMENT WAS ACKNOWLEDGED BEFORE ME BY _____ (NAME),

_____ (TITLE), OF _____

THIS THE _____ DAY OF _____, 20____,

NOTARY PUBLIC, IN AND FOR THE STATE OF TEXAS

STATE OF TEXAS §
COUNTY OF NUECES §

THE FINAL PLAT OF THE HEREIN DESCRIBED PROPERTY WAS APPROVED BY THE DEPARTMENT OF DEVELOPMENT SERVICES OF THE CITY OF CORPUS CHRISTI, TEXAS

GABRIEL HINOJOSA, P.E.
DEVELOPMENT SERVICES ENGINEER

DATE

STATE OF TEXAS §
COUNTY OF NUECES §

THE FINAL PLAT OF THE HEREIN DESCRIBED PROPERTY WAS APPROVED ON BEHALF OF THE CITY OF CORPUS CHRISTI, TEXAS BY THE PLANNING COMMISSION.

THIS THE _____ DAY OF _____, 20____,

ERIC VILLARREAL, P.E.
CHAIRMAN

NINA NIXON-MÉNDEZ, FAICP
SECRETARY

STATE OF TEXAS §
COUNTY OF NUECES §

I, KARA SANDS, CLERK OF THE COUNTY COURT IN AND FOR SAID COUNTY, DO HEREBY CERTIFY THAT THE FOREGOING INSTRUMENT DATED THE _____ DAY OF _____, 20____ WITH ITS CERTIFICATE OF AUTHENTICATION, WAS FILED FOR RECORD IN MY OFFICE THE _____ DAY OF _____, 20____ AT _____ O'CLOCK _____M., AND DULY RECORDED THE _____ DAY OF _____, 20____ AT _____ O'CLOCK _____M. IN THE MAP RECORDS OF SAID COUNTY IN VOLUME _____, PAGE _____, INSTRUMENT NUMBER _____, WITNESS MY HAND AND SEAL OF THE COUNTY COURT IN AND FOR SAID COUNTY AT OFFICE IN CORPUS CHRISTI, NUECES COUNTY, TEXAS, THE DAY AND YEAR LAST WRITTEN.

BY: _____

DEPUTY

KARA SANDS, CLERK
COUNTY COURT
NUECES COUNTY, TEXAS

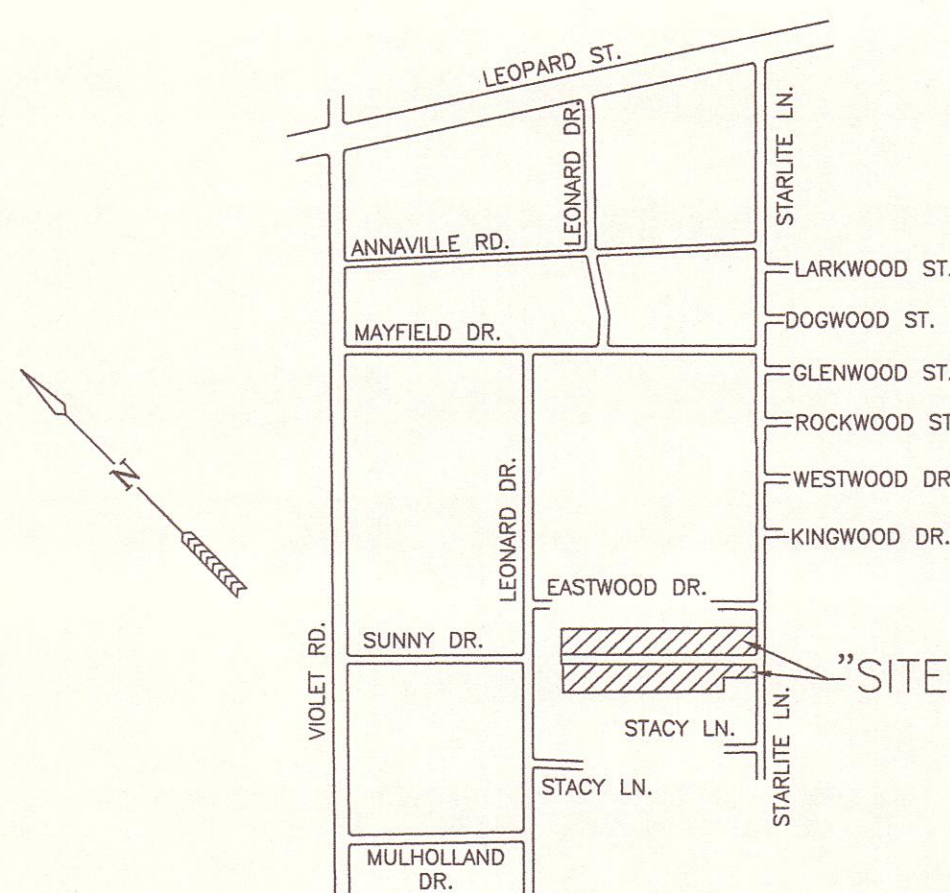

LOCATION MAP
1"=1200'

PLAT OF WESTWOOD HEIGHTS UNIT 4

A 4.744 ACRE TRACT IN BLOCK 1 AS SHOWN ON THE FOLLOWING SHEET, A PORTION OF NUECES GARDENS NO. 2, LOT 43, A MAP OF WHICH IS RECORDED IN VOLUME 10, PAGE 8, MAP RECORDS, NUECES COUNTY, TEXAS AND A 4.315 ACRE TRACT IN BLOCK 2 AS SHOWN ON THE FOLLOWING SHEET, A PORTION OF LOT 42, SAID NUECES GARDENS NO. 2, FOR A TOTAL OF 9.059 ACRES INCLUDING STREET DEDICATIONS

CORPUS CHRISTI, NUECES COUNTY, TEXAS

BASS & WELSH ENGINEERING
SURVEY REG. NO. 100027-00,
TX ENGINEERING REG. NO. F-52
3054 S. ALAMEDA STREET, CORPUS CHRISTI, TEXAS 78404

DATE PLOTTED: 10/10/19
COMP. NO.: PLAT-SH.DWG
JOB NO.: 18073
SCALE: 1" = 60'
PLOT SCALE: SAME
SHEET 1 OF 2

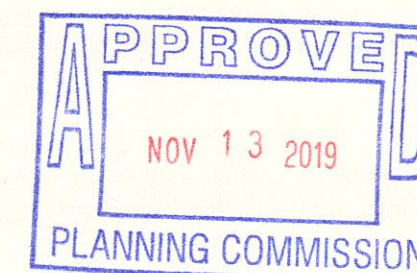

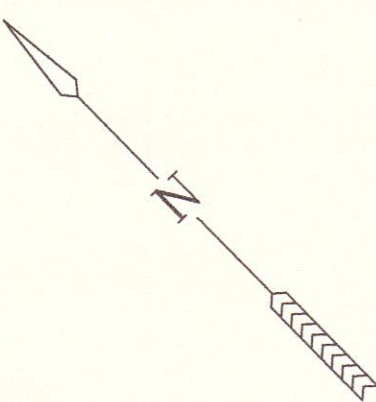
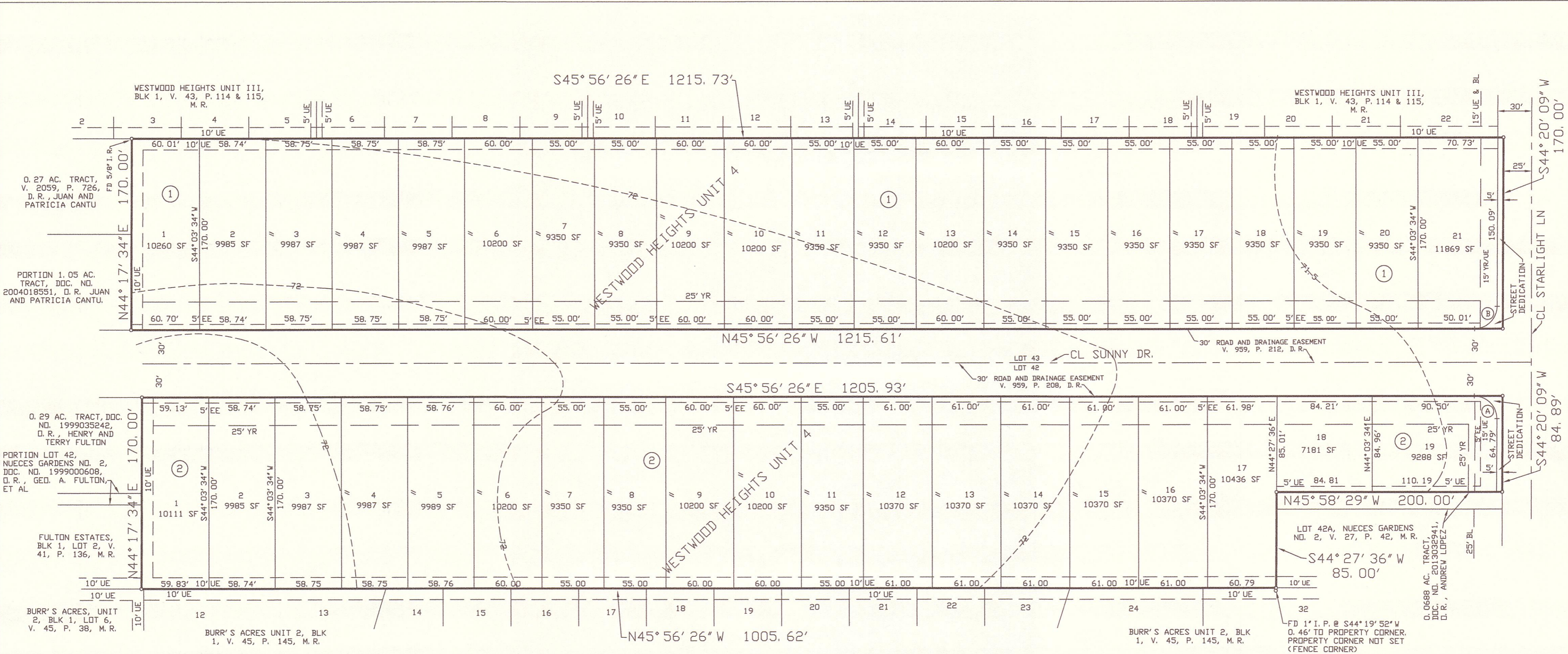

NOTES:

1. THE BASIS OF BEARINGS IS THE STATE OF TEXAS LAMBERT GRID, SOUTH ZONE, NAD 1983.
2. THE SUBJECT SITE IS DEPICTED IN FEMA MAP 48355C0280G (10/23/15), ZONE X, 0.2% ANNUAL CHANCE FLOOD.
3. THE SUBJECT SITE CONTAINS 4.744 ACRES IN BLOCK 1 AND 4.315 ACRES IN BLOCK 2, FOR A TOTAL OF 9.059 ACRES INCLUDING STREET DEDICATIONS.
4. THE RECEIVING WATER FOR THE STORM WATER RUNOFF FROM THIS PROPERTY IS THE CORPUS CHRISTI INNER HARBOR. THE TCEQ HAS CLASSIFIED THE AQUATIC LIFE USE FOR THE CORPUS CHRISTI INNER HARBOR AS 'INTERMEDIATE'.
5. THE YARD REQUIREMENT, AS DEPICTED, IS A REQUIREMENT OF THE UNIFIED DEVELOPMENT CODE AND IS SUBJECT TO CHANGE AS THE ZONING MAY CHANGE.
6. SET 5/8" IRON RODS AT ALL LOT CORNERS UNLESS OTHERWISE INDICATED. ALL IRON RODS SET CONTAIN PLASTIC CAPS LABELED "BASS AND WELSH ENGINEERING".
7. THE MINIMUM FINISHED FLOOR ELEVATION FOR STRUCTURES ON LOTS THIS SUBDIVISION SHALL BE 21' ABOVE THE HIGHEST CENTER OF FRONTING STREET PAVING ELEVATION.
8. THERE ARE NO KNOWN NATURAL WATER BODIES, JURISDICTIONAL WETLANDS, ENDANGERED SPECIES HABITAT, STATE SUBMERGED LANDS OR CRITICAL DUNES ON THE SITE.
9. NO DRIVEWAY ACCESS TO STARLIGHT LANE.
10. LOT 21, BLOCK 1 & LOT 19, BLOCK 2 MUST BE REQUIRED TO ADHERE TO VISIBILITY TRIANGLE REQUIREMENTS OF UDC SECTION 4.2.9.

CURVE DATA

(A)	(B)
D=90° 16' 35"	D=89° 43' 25"
R=20.00'	R=20.00'
T=20.10'	T=19.90'
L=31.51'	L=31.32'
CB=N00° 48' 08" W	CB=S89° 11' 52" W
CH=28.35'	CH=28.22'



PLAT OF WESTWOOD HEIGHTS UNIT 4

A 4.744 ACRE TRACT IN BLOCK 1, A PORTION OF NUECES GARDENS NO. 2, LOT 43, A MAP OF WHICH IS RECORDED IN VOLUME 10, PAGE 8, MAP RECORDS, NUECES COUNTY, TEXAS AND A 4.315 ACRE TRACT IN BLOCK 2, A PORTION OF LOT 42, SAID NUECES GARDENS NO. 2, FOR A TOTAL OF 9.059 ACRES INCLUDING STREET DEDICATIONS.

CORPUS CHRISTI, NUECES COUNTY, TEXAS

BASS & WELSH ENGINEERING
 FIRM NO. F-52, 3054 S. ALAMEDA ST.
 CORPUS CHRISTI, TEXAS 78404

DATE PLOTTED: 10/23/19
 COMP. NO.: PLAT-SH2
 JOB NO.: 18073
 SCALE: 1" = 60'
 PLOT SCALE: SAME
 SHEET 2 OF 2

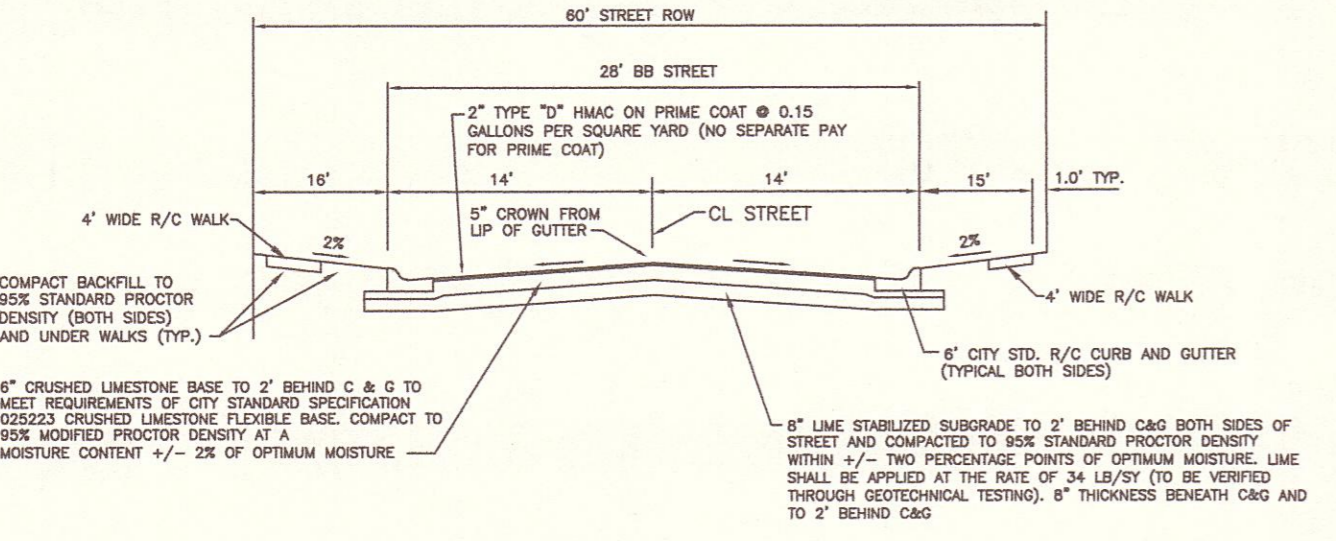

TYPICAL STREET SECTION - 60' ROW

N.T.S.

EXHIBIT 2

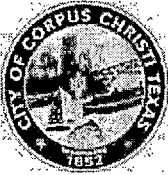

Reimbursement Agreement Application

Development Services Department

Submit the Application to: contractsandagreements@cctexas.com

Mail to: City of Corpus Christi Development Services
2406 Leopard St. Suite 100
Corpus Christi, Texas 78408

Date: 5.2.22

Approved Plat Name: Westwood Heights Unit 4

Type of Public Improvements: water & Sanitary line

Ownership and authorized signatories to enter into the agreement:

Requested duration of agreement: 24 Months

Point of Contact Information:

Contact Name: Navid Zarghooni

Contact Number: 361.946.8208

Name of Company Entering into the agreement (L.L.C.; L.P., Inc.):

Devonshire Custom Homes, Inc

Address: 2129 Airline Rd

City: C.C. State: TX ZIP: 78414

Phone Number: 361.946.8208

The items listed below are required before an application can be processed:

- 1) Application for reimbursement per UDC Section 8.5.1 or 8.5.2
- 2) \$535.00 application fee for new agreements and addendums
- 3) Planning Commission approved plat (Final or Master Preliminary)
- 4) Cost estimate for project from a registered engineer
- 5) Public improvement plans or design memorandum
- 6) Warrantee Deed for the property associated with the project
- 7) Disclosure of Interest Form
- 8) Form 1295, a W-9 Form, and a Corporate Resolution

[Signature]
Applicant's Signature

President
Title

EXHIBIT 3

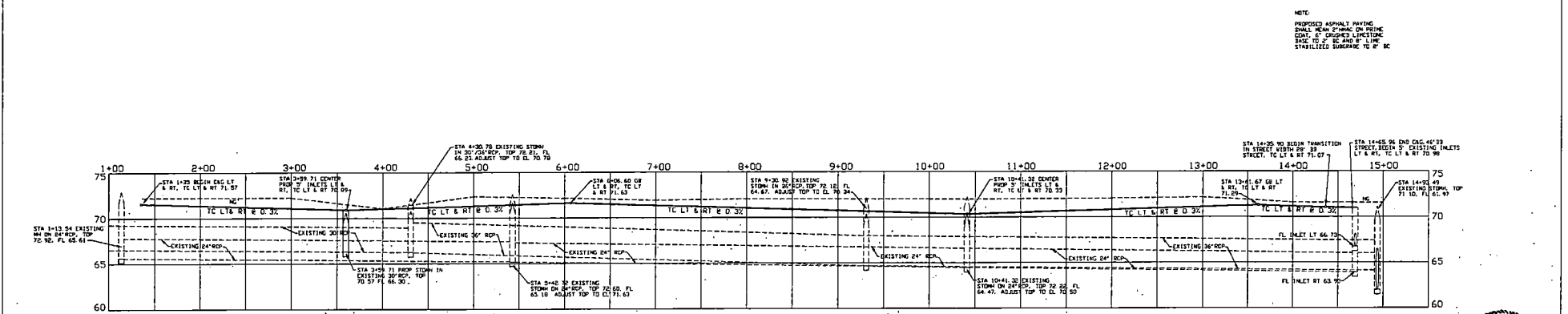
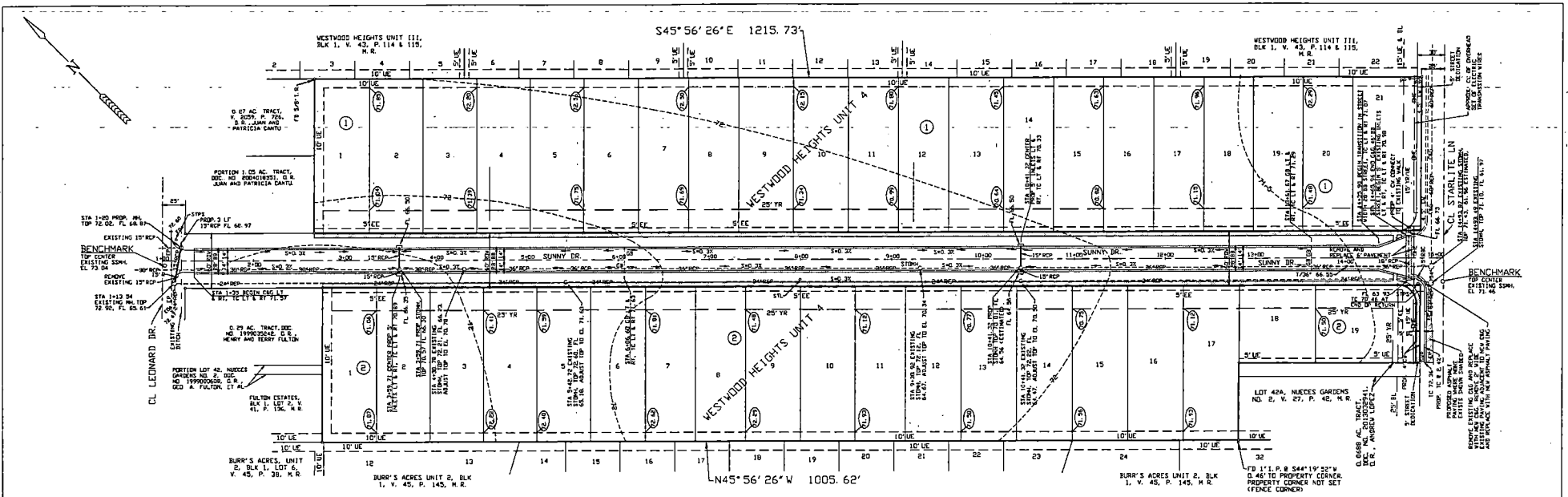

PROFILE - SUNNY DR.



PLANS ARE RELEASED FOR CONSTRUCTION DEVELOPMENT SERVICES
 Construction plans will expire based on conditions stated in UDC 3.8.5.F (August 2016)

Digitally signed by Jalal M.H. Ali Saleh, P.E.
 DN: cn=Jalal M.H. Ali Saleh, P.E., o=City of Corpus Christi, ou=Development Services, email=jalals@cctexas.com, c=US
 Date: 2020.12.15 16:36:30 -06'00'

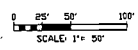

BASS & WELSH ENGINEERING TX SURVEY REG. NO. 100027-00, TX ENGINEERING REG. NO. F-52, 3054 S. ALAMEDA STREET, CORPUS CHRISTI, TEXAS 78404			
PUBLIC IMPROVEMENTS TO WESTWOOD HEIGHTS UNIT 4 CORPUS CHRISTI, NUECES COUNTY, TEXAS			
PAYING, GRADING AND DRAINAGE PLAN STREET AND STORM SEWER PROFILES			
DRG. NO.	DATE PLOTTED	12/15/20	SHEET 2 OF 2

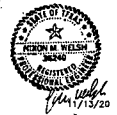

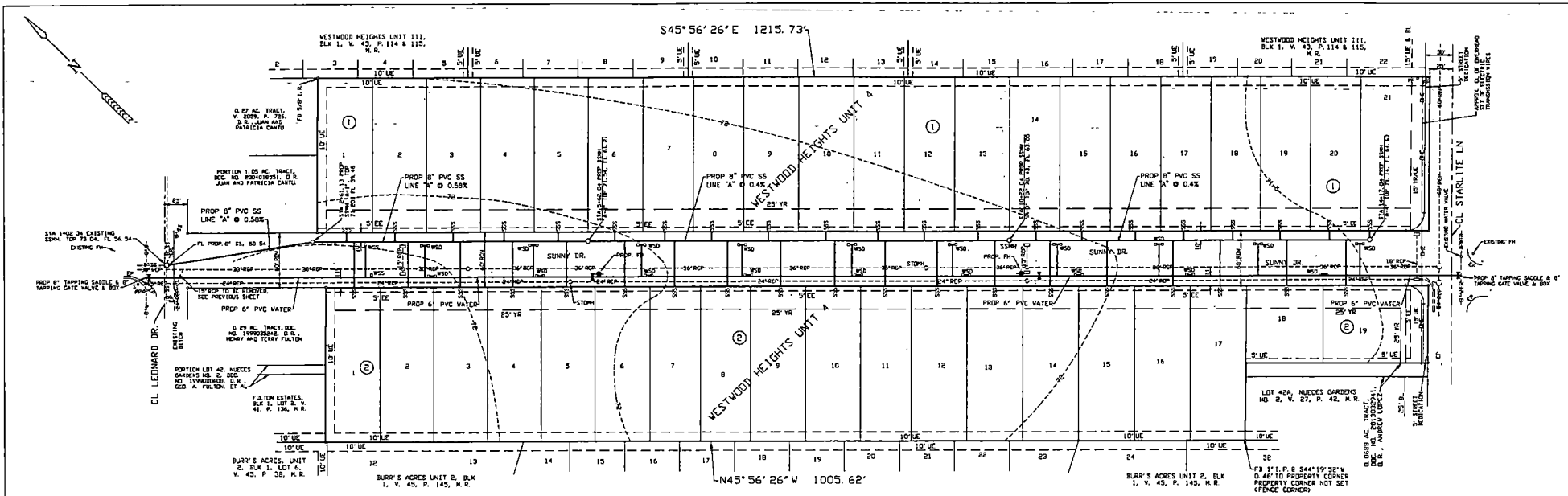

NOTE:
 CONTRACTOR SHALL VERIFY ALL SANITARY SEWER SERVICES
 WILL CLEAN EXISTING STORM SEWER PIPES PRIOR TO ANY
 STREET CONSTRUCTION

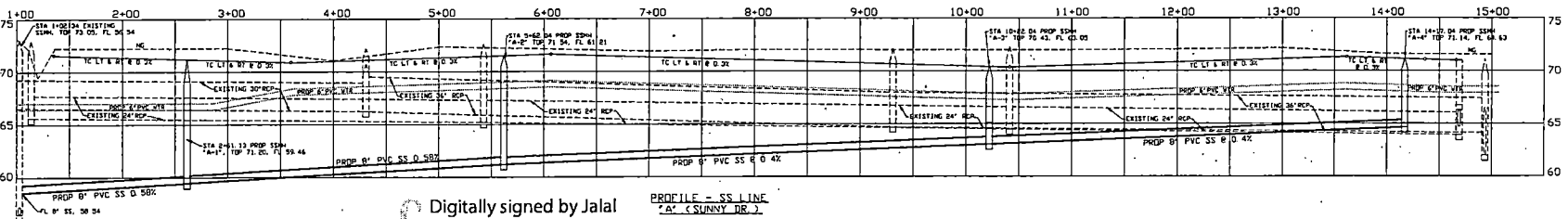

PROFILE - SS LINE
 "A" (SUNNY DR.)

PLANS ARE RELEASED FOR
 CONSTRUCTION
 DEVELOPMENT SERVICES
 City of
 Corpus
 Christi

Digitally signed by Jalal
 M.H. Ali Saleh, P.E.
 DN: cn=Jalal M.H. Ali
 Saleh, P.E., o=City of
 Corpus Christi,
 ou=Development
 Services,
 email=jalal@cctexas.co
 m, c=US
 Date: 2020.12.15
 16:36:55 -06'00'



BASS & WELSH ENGINEERING TX SURVEY REG. NO. 100027-00, TX ENGINEERING REG. NO. F-52, 3054 S. ALAMEDA STREET, CORPUS CHRISTI, TEXAS 78404			
PUBLIC IMPROVEMENTS TO WESTWOOD HEIGHTS UNIT 4 CORPUS CHRISTI, NUECES COUNTY, TEXAS			
SANITARY SEWER AND WATER PLAN AND PROFILE			
DRW. B. WELSH	PLT. SCALE 1" = 50'	CON. NO. 18533	PROJ. NO. 18533
DATE 11/13/20	SCALE 0'S 1" = 50'	JOB NO. 18533	SHEET 3 OF 3

0 25' 50' 100'
 SCALE: 1" = 50'

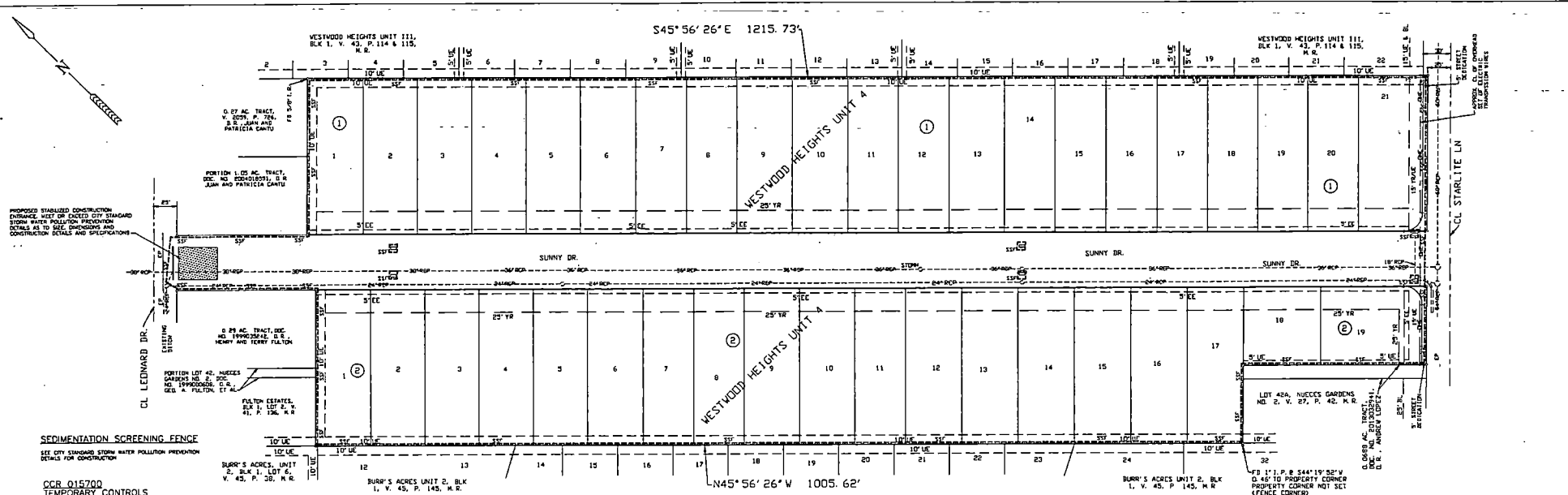

SEDIMENTATION SCREENING FENCE
SEE CITY STANDARD STORM WATER POLLUTION PREVENTION DETAILS AS TO SIZE, SPACING AND CONSTRUCTION DETAILS AND SPECIFICATIONS

**OCR 015700
TEMPORARY CONTROLS**

ALL STORM WATER POLLUTION WORK SHALL BE DONE IN ACCORDANCE WITH THE CITY STANDARD SPECIFICATIONS FOR STORM WATER POLLUTION PREVENTION. THE OPERATOR SHALL BE RESPONSIBLE FOR OBTAINING PERMITS FROM THE CITY ENGINEERING SERVICES DEPARTMENT ON LINE AT THE CITY'S WEB SITE. ENGINEERING SERVICES DEPARTMENT, PROJECT STANDARDS AND CONTRACTS, FROM THE CONSTRUCTION CONTRACT DOCUMENTS, DIVISION 02.

POLLUTION PREVENTION NOTES

- CONSTRUCTION ENTRANCE - CONVECT A PROPOSED 2' x 30' CONSTRUCTION ENTRANCE CONSISTING OF AN AREA SURFACED WITH DRY STONE OR GRAVEL OF SIZE 2" TO 3" DIA. THE GRAVEL OR COARSE STONE SHALL BE PLACED TO A MINIMUM 6" THICK LAYER AND FURTHER COVERED BY A LAYER OF FILTER FABRIC MEETING THE SAME REQUIREMENTS AS THE SILL FENCE. THE OPERATOR SHALL MAINTAIN THE CONSTRUCTION ENTRANCE IN GOOD CONDITION THROUGHOUT THE DURATION OF THE PROJECT AND SHALL REMOVE MUD OR OTHER DEBRIS FROM THE CONSTRUCTION ENTRANCE PERIODICALLY DURING THE PROJECT.
- CONSTRUCTION EQUIPMENT TRACKING - CONTRACTORS SHALL ENSURE THAT NO MUD OR ANY OTHER DEBRIS BE TRACKED ONTO PAVED STREETS IN THE AREA OF THIS PROJECT. SHOULD ANY MUD OR OTHER DEBRIS BE TRACKED ONTO PAVED STREETS, CONTRACTOR SHALL IMMEDIATELY CLEANUP SAME AT HIS OWN EXPENSE.
- SILT SCREENS - CONTRACTOR SHALL SCREENS AT LOCATIONS AS SHOWN IN THE PLANS. ALL SILT SCREENS SHALL MEET THE REQUIREMENTS OF CITY STANDARD SPECIFICATION GRADE SILT FENCE. THE SILT FENCES SHALL BE INSPECTED THROUGHOUT THE CONSTRUCTION PERIOD ON A DAILY BASIS AND SHALL BE REPAIRED/REPLACED AS NECESSARY.
- SOLID WASTE DISPOSAL - ALL TRASH AND DEBRIS WILL BE HAULED TO AN APPROVED LANDFILL. NO CONSTRUCTION WASTE MATERIAL WILL BE BURIED ON-SITE. ALL PERSONNEL WILL BE INSTRUCTED REGARDING THE CORRECT PROCEDURE FOR WASTE DISPOSAL. NOTICES STATING THESE PRACTICES SHALL BE POSTED AT THE JOB SITE.
- HAZARDOUS WASTE - NO HAZARDOUS WASTE IS EXPECTED TO BE GENERATED OR ENCOUNTERED IN THIS PROJECT. IN THE EVENT THAT HAZARDOUS WASTE IS ENCOUNTERED, ALL HAZARDOUS WASTE MATERIALS WILL BE DISPOSED OF IN THE MANNER SPECIFIED BY LOCAL OR STATE REGULATIONS OR BY THE MANUFACTURER.
- SPILL PREVENTION - THE FOLLOWING ARE THE MATERIAL HANDLING PRACTICES THAT WILL BE USED TO PREVENT THE RISK OF SPILLS OF TOXIC MATERIALS, EXPLOSIVES OR MATERIALS THAT SUBSTANCES TO STORM WATER RUNOFF. AN OFFICE WILL BE MAINTAINED ON-SITE THROUGHOUT THE PROJECT DURATION TO THIS JOB. ALL MATERIALS TO BE STORED IN A LEAK TIGHT CONTAINER. PRODUCTS WILL BE KEPT IN THEIR ORIGINAL CONTAINERS WITH THE ORIGINAL MANUFACTURER'S INFORMATION. IF PRODUCTS ARE TO BE STORED IN A CONTAINER OTHER THAN THE ORIGINAL MANUFACTURER'S CONTAINER, ALL OF THE PRODUCT WILL BE KEPT IN A LEAK TIGHT CONTAINER. CONTRACTOR SHALL BE RESPONSIBLE FOR PROPER USE AND DISPOSAL WILL BE FOLLOWING THE SITE SUPERINTENDENT WILL IMPROVE DAILY TO DETERMINE PROPER USE AND DISPOSAL OF MATERIALS. FUELING OF CONSTRUCTION VEHICLES SHALL BE MADE A MINIMUM OF 500' AWAY FROM ANY DRAINAGE INLET OR SHALE.
- ANY FOD SILT SCREENS FENCES, STABILIZED CONSTRUCTION ENTRANCE AND ALL POLLUTION PREVENTION MEASURES OF ALL TYPES IN THE MIDDLE OF "STORM WATER POLLUTION PREVENTION" SHALL BE MAINTAINED BY THE OPERATOR.
- CONTRACTOR SHALL ENSURE THAT THE SITE IS CONTROLLED (NOT ALLOWED TO BLOW TO ADJACENT PROPERTIES) BY DRAINING DURING CONSTRUCTION.
- CONCRETE TRUCKS WILL NOT BE ALLOWED TO WASH OUT ANYWHERE ON THE PROJECT SITE UNLESS THE TRUCKS' CONCRETE OR DRY MIX BASH WATER IN CONCRETE TRUCKS IS DISCHARGED AT THE CONSTRUCTION SITE THAT WILL RETURN ALL CONCRETE WASH WATER OR LEAKAGE WATER TO THE WASTE WATER TREATMENT PLANT. WASH WATER AND LEAKAGE WATER INCLUDING ANY WASH WATER TUBS SHALL BE RETURNED TO THE WASTE WATER TREATMENT PLANT. THE WATERS OF THE UNITED STATES OR OF ANY STATE OR TERRITORY SHALL NOT BE POLLUTED.
- NON-GENERATE TRUCK VEHICLES SHALL BE WASHED AT THE STABILIZED CONSTRUCTION ENTRANCE IN A MANNER TO REMOVE ALL MUD AND DEBRIS FROM THE TRUCKS.
- THE TEXAS POLLUTANT DISCHARGE EXAMINATION SYSTEM (TPDES) GENERAL POINT REQUIREMENTS SHALL BE INITIATED AS SOON AS PRACTICABLE IN PORTIONS OF THE SITE WHERE CONSTRUCTION ACTIVITIES ARE TO BE INITIATED AND SHALL BE MAINTAINED THROUGHOUT THE CONSTRUCTION PERIOD. ANY PART OF THE SITE THAT IS TEMPORARILY OR PERMANENTLY CEASED CONSTRUCTION TEMPORARILY CEASED - "WINDSHIELD WASH" AS SOON AS PRACTICABLE, BUT NO LATER THAN THE END OF THE NEXT BUSINESS DAY EXCEPT WHERE TEMPORARY STABILIZATION IS NECESSARY. TEMPORARY PREVENTION CONTROLS ARE UTILIZED INSTEAD THE OPERATOR MUST DOCUMENT WHY STABILIZATION IS NECESSARY AND DOCUMENT THAT PREVENTION CONTROLS WILL BE MAINTAINED THROUGHOUT THE CONSTRUCTION PERIOD. TEMPORARILY CEASED CONSTRUCTION TEMPORARILY CEASED - "WINDSHIELD WASH" AS SOON AS PRACTICABLE, BUT NO LATER THAN THE END OF THE NEXT BUSINESS DAY EXCEPT WHERE TEMPORARY STABILIZATION IS NECESSARY. TEMPORARY PREVENTION CONTROLS ARE UTILIZED INSTEAD THE OPERATOR MUST DOCUMENT WHY STABILIZATION IS NECESSARY AND DOCUMENT THAT PREVENTION CONTROLS WILL BE MAINTAINED THROUGHOUT THE CONSTRUCTION PERIOD.

ESTIMATE SUMMARY

ITEM DESCRIPTION	QUANTITY	UNIT	ITEM DESCRIPTION	QUANTITY	UNIT
1. 1" ASPHALT	89	LF	1. 1" PVC PIPE	1140	LF
2. MANHOLE	3	EA	2. FIBROGLASS MANHOLE	4	EA
3. ADJUST MANHOLE TOP	4	EA	3. 4" OR 6" PVC PIPE SERVICE	40	EA
4. 6" LINE STABILIZED SUBGRADE TO 2' DC	4421	SF			
5. 6" CRUSHED Limestone BASE TO 2' DC	4421	SF			
6. LEONARD	1	LS			
7. CLEANING & CURBING	1078	AC			
8. STOP SIGN	1	EA			
STORM SEWER ITEMS	QUANTITY	UNIT	WATER ITEMS	QUANTITY	UNIT
1. 12" RCP	89	LF	1. 12" RCP	89	LF
2. MANHOLE	3	EA	2. MANHOLE	3	EA
3. ADJUST MANHOLE TOP	4	EA	3. ADJUST MANHOLE TOP	4	EA
STORM SEWER ITEMS REMBURSABLE BY CITY	QUANTITY	UNIT	WATER ITEMS REMBURSABLE BY CITY	QUANTITY	UNIT
1. 12" PVC PIPE	1140	LF	1. 12" PVC PIPE	1140	LF
2. 12" PVC PIPE	1140	LF	2. 12" PVC PIPE	1140	LF
3. PATCH PAVEMENT	1	LS	3. PATCH PAVEMENT	1	LS
MISCELLANEOUS ITEMS	QUANTITY	UNIT	MISCELLANEOUS ITEMS	QUANTITY	UNIT
1. TRAFFIC CONTROL AND BARRICADING PLAN AND PERMITTING TRAFFIC CONTROL DURING CONSTRUCTION	1	LS	1. TRAFFIC CONTROL AND BARRICADING PLAN AND PERMITTING TRAFFIC CONTROL DURING CONSTRUCTION	1	LS
2. TRENCH SAFETY FOR EXCAVATIONS SANITARY SEWER AND STORM SEWER PIPES OF ALL SIZES	1927	LF	2. TRENCH SAFETY FOR EXCAVATIONS SANITARY SEWER AND STORM SEWER PIPES OF ALL SIZES	1927	LF
3. 4" PVC CONDUIT FOR ACP	180	LF	3. 4" PVC CONDUIT FOR ACP	180	LF
4. STORM WATER POLLUTION PREVENTION	1	LS	4. STORM WATER POLLUTION PREVENTION	1	LS

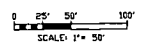
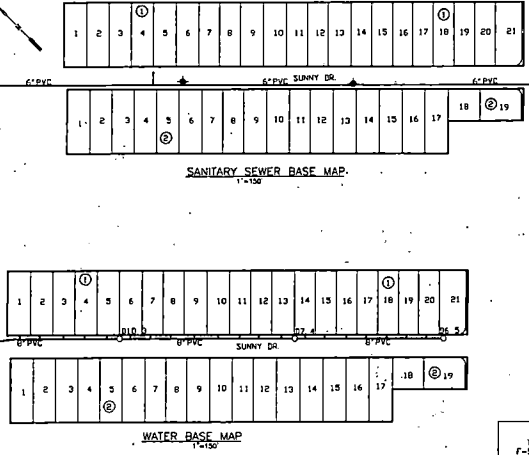

Digitally signed by Jalal M.H. Ali Saleh, P.E.
DN: cn=Jalal M.H. Ali Saleh, P.E., o=City of Corpus Christi, ou=Development Services, email=jalals@cctx.as.com, c=US
Date: 2020.12.15 16:37:18 -06'00'



BASS & WELSH ENGINEERING
TX SURVEY REG. NO. 100027-00, TX ENGINEERING REG. NO. F-52, 3054 S. ALAMEDA STREET, CORPUS CHRISTI, TEXAS 78404

PUBLIC IMPROVEMENTS TO WESTWOOD HEIGHTS UNIT 4 CORPUS CHRISTI, NUECES COUNTY, TEXAS

STORM WATER POLLUTION PREVENTION PLAN, ESTIMATE SUMMARY AND BASE MAPS

DATE PLOTTED: 11/13/20

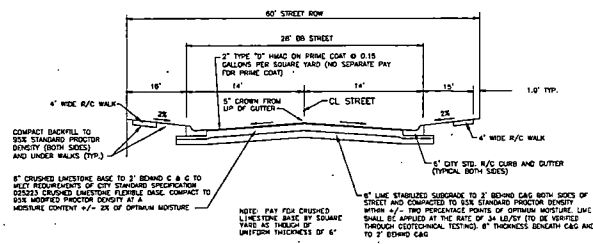

TYPICAL STREET SECTION - 60' ROW

TENSAR GEOGRID
 TENSAR GEOTEXTILES (OR PRE-APPROVED EQUAL) MAY BE USED IN LIEU OF 6" LINE STABILIZED SUBGRADE. PLACE GEO GRID TO 2" BE AND COMPACTED IN ACCORDANCE WITH THE MANUFACTURER'S RECOMMENDATIONS. CRUSHED LIMESTONE BASE SHALL DISPLAY 95% (95) RELATIVE COMPACTION. CONTACT TENSAR (OR LIEU OF) 6" LINE STABILIZED SUBGRADE FOR ALL STREET SECTIONS (NO SPANWAY PAV). CONTACT TENSAR IN ACCORDANCE WITH CITY STANDARD SPECIFICATION SECTION AND THE MANUFACTURER'S RECOMMENDATIONS. IF GEOTEXTILE IS USED, PROVIDE 8" (MINIMUM) THICKNESS COMPACTED CRUSHED LIMESTONE BASE IMMEDIATELY ABOVE THE GEOTEXTILE.



PLANS ARE RELEASED FOR CONSTRUCTION DEVELOPMENT SERVICES. Construction plans will expire based on conditions stated in UDC 3.8.5.2 (August 2016).

Digitally signed by Jalal M.H. Ali Saleh, P.E.
 DN: cn=Jalal M.H. Ali Saleh, P.E., o=City of Corpus Christi, ou=Development Services,
 email=jalal@cctexas.com, c=US
 Date: 2020.12.15 16:37:43 -06'00'

POZ-LOC SIGN SUPPORT POST AND SOCKET SYSTEM

THE POZ-LOC SIGN SUPPORT POST ANCHOR SYSTEM IS A TUBULAR SOCKET SYSTEM DESIGNED TO BE USED FOR TYPE 1 SMALL TRAFFIC SIGN SUPPORTS. THE ASSEMBLY CONSISTS OF:

1. A GALVANIZED 2-3/8" O.D. TRAFFIC SIGN POST WITH A MINIMUM WALL THICKNESS OF .063".
2. A TUBULAR SOCKET 2-1/2" O.D. X 12 GA. WALL THICKNESS X 37" LONG. THE SOCKET IS POINTED TO FACILITATE DRIVING INTO THE GROUND AND TO ACCEPT A STANDARD 2-3/8" TRAFFIC SIGN POST, WHICH INSERTS INTO THE SOCKET.
3. A WEDGE WHICH IS DRIVEN BETWEEN THE SOCKET AND THE GROUND TO LOCK THE POST INTO THE SOCKET.

IF THE WEDGE IS DAMAGED, OR OTHERWISE NEEDS TO BE REMOVED, THE WEDGE CAN BE REMOVED WITH A WEDGE PULLER. ANOTHER POST INSERTED, AND THE WEDGE REPLACED WITHOUT INTERRUPTING THE FLOWING. THE USE OF A SPECIAL WEDGE PULLER DISCOURAGES VANDALISM OF THE SIGN SYSTEM.

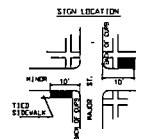

SIGN LOCATION SHALL BE IN THE AREAS SHADED IN THE ABOVE DIAGRAM

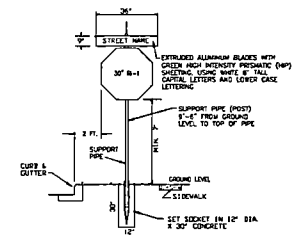

STOP SIGN INSTALLATION FOR RESIDENTIAL INTERSECTIONS

- NOTES:
1. ALL STREET NAME BLADES SHALL BE 6" TALL EXTRUDED ALUMINUM BLADES WITH GREEN HIGH INTENSITY PRESATIC COPY SETTING LOGIC WITH 8" TALL CAPITAL LETTERS AND LOWER CASE LETTERING.
 2. TRIANGULAR SLIP BASE SYSTEMS ARE REQUIRED FOR STOP SIGN SUPPORTS THIS PROJECT.

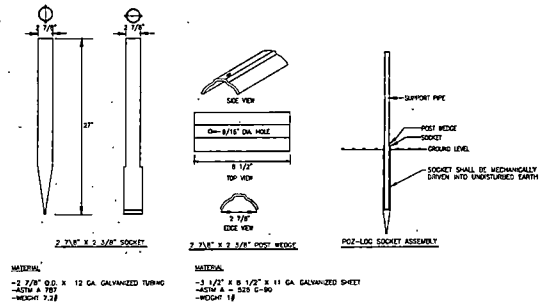

MATERIAL:
 -2 3/8" O.D. X 37" L. GALVANIZED TUBING
 -WTH # 100
 -WEGHT 3.28

MATERIAL:
 -2 1/2" X 2 3/8" X 11 GA. GALVANIZED SHEET
 -WTH # 100
 -WEGHT 1.8

POZ-LOC SIGN SUPPORT ASSEMBLY



BASS AND WELSH ENGINEERING			
TX REGISTRATION NO. F-52, 3034 S. ALAMEDA STREET, CORPUS CHRISTI, TEXAS 78404			
PUBLIC IMPROVEMENTS TO VESTWOOD HEIGHTS UNIT 4, CORPUS CHRISTI, NUECES CO., TX			
STREET AND SIDEWALK DETAILS			
DRW. - H. WELSH	PLAT SCALE 1" = 50'	CON. NO. - 18073	SIB. NO.
	SCALE (H) - AS SHOWN	JOB NO.	
	SCALE (V) - AS SHOWN	408	
	DATE PLOTTED 11/13/20	SHEET 5 OF 5	

EXHIBIT 4

NIXON M. WELSH, P.E., R.P.L.S.
Email: NixMW@aol.com

BASS WELSH ENGINEERING
TX Registration No. F-52
Survey Registration No. 100027-00
P.O. Box 6397
Corpus Christi, TX 78466-6397

3054 S. Alameda St.

18073-PCE-SS
09/03/24

**WESTWOOD HEIGHTS
SANITARY SEWER REIMBURSEMENT ESTIMATE**

SANITARY SEWER ITEMS, REIMBURSABLE BY CITY		QUANTITY	UNIT	AMOUNT	
1	8" PVC PIPE	162	LF	110.00	17,820.00
2	PATCH PAVEMENT	1	LS	8,500.00	8,500.00

TOTAL SANITARY SEWER ITEMS \$26,320.00

NOTE: PRICES SHOWN AS FURNISHED BY DEVELOPER

10% ENGINEERING, SURVEYING, & TESTING 2,632.00

SUB-TOTAL \$28,952.00

MAXIMUM REIMBURSEMENT OF ABOVE SUB-TOTAL= 50%= 14,476.00

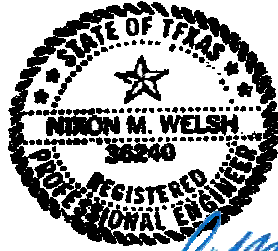

A handwritten signature in blue ink that reads "Nixon M. Welsh".