

NUECES ACRES UNIT 2, BLOCK 1, LOT 24E and 24F

BEING A REPLAT OF NUECES ACRES UNIT 2, BLOCK 1, LTS 24A, 24B, 24C & 24D DESCRIBED IN DEED 2026014551, DEED RECORDS OF NUECES COUNTY, TEXAS,



LOCATION MAP
NOT TO SCALE

STATE OF TEXAS
COUNTY OF NUECES
I, JIOLA SALMAN, HEREBY CERTIFY THAT I AM THE OWNER OF THE LANDS EMBRACED WITHIN THE BOUNDARIES OF THE FORGOING PLAT; THAT IT HAS HAD SAID LAND SURVEYED AND SUBDIVIDED AS SHOWN; THAT STREETS AS SHOWN ARE DEDICATED TO THE PUBLIC FOREVER; THAT ALL EASEMENTS ARE DEDICATED TO THE PUBLIC FOR THE INSTALLATION, OPERATION, AND USE OF PUBLIC UTILITIES; THAT THIS MAP WAS MADE FOR THE PURPOSE OF DESCRIPTION AND DEDICATION.

THIS THE _____ DAY OF _____ 2026.

JIOLA SALMAN
OWNER

STATE OF TEXAS
COUNTY OF NUECES
THIS INSTRUMENT WAS ACKNOWLEDGED BEFORE ME BY
JIOLA SALMAN.

THIS THE _____ DAY OF _____ 2026.

NOTARY PUBLIC IN AND FOR THE STATE OF TEXAS

STATE OF TEXAS
COUNTY OF NUECES
THIS FINAL PLAT OF THE HEREIN DESCRIBED PROPERTY WAS APPROVED BY THE
PLANNING COMMISSION FOR THE CITY OF CORPUS CHRISTI, TEXAS.

THIS THE _____ DAY OF _____ 2026.

MICHAEL DICE, INTERIM ASST. CITY MANAGER

CYNTHIA SALAZAR-GARZA, CHAIRPERSON

STATE OF TEXAS
COUNTY OF NUECES
THIS FINAL PLAT OF THE HEREIN DESCRIBED PROPERTY WAS APPROVED BY THE
DEVELOPMENT SERVICES ENGINEER OF THE CITY OF CORPUS CHRISTI, TEXAS.

THIS THE _____ DAY OF _____ 2026.

BRIA WHITMIRE, P.E. CFM. CPM
DEVELOPMENT SERVICES ENGINEER

STATE OF TEXAS
COUNTY OF NUECES
I, JARREL L. MOORE, A REGISTERED PROFESSIONAL LAND SURVEYOR HEREBY CERTIFY THAT THE FOREGOING PLAT WAS PREPARED FROM A SURVEY MADE ON THE GROUND UNDER MY DIRECTION AND IS TRUE AND CORRECT; THAT I HAVE BEEN ENGAGED UNDER CONTRACT TO SET ALL LOT AND BLOCK CORNERS AND COMPLETE SUCH OPERATIONS WITHOUT DELAY.

THIS THE 11th DAY OF May 2026.

JARREL L. MOORE
REGISTERED PROFESSIONAL LAND SURVEYOR
LICENSE NO. 4854

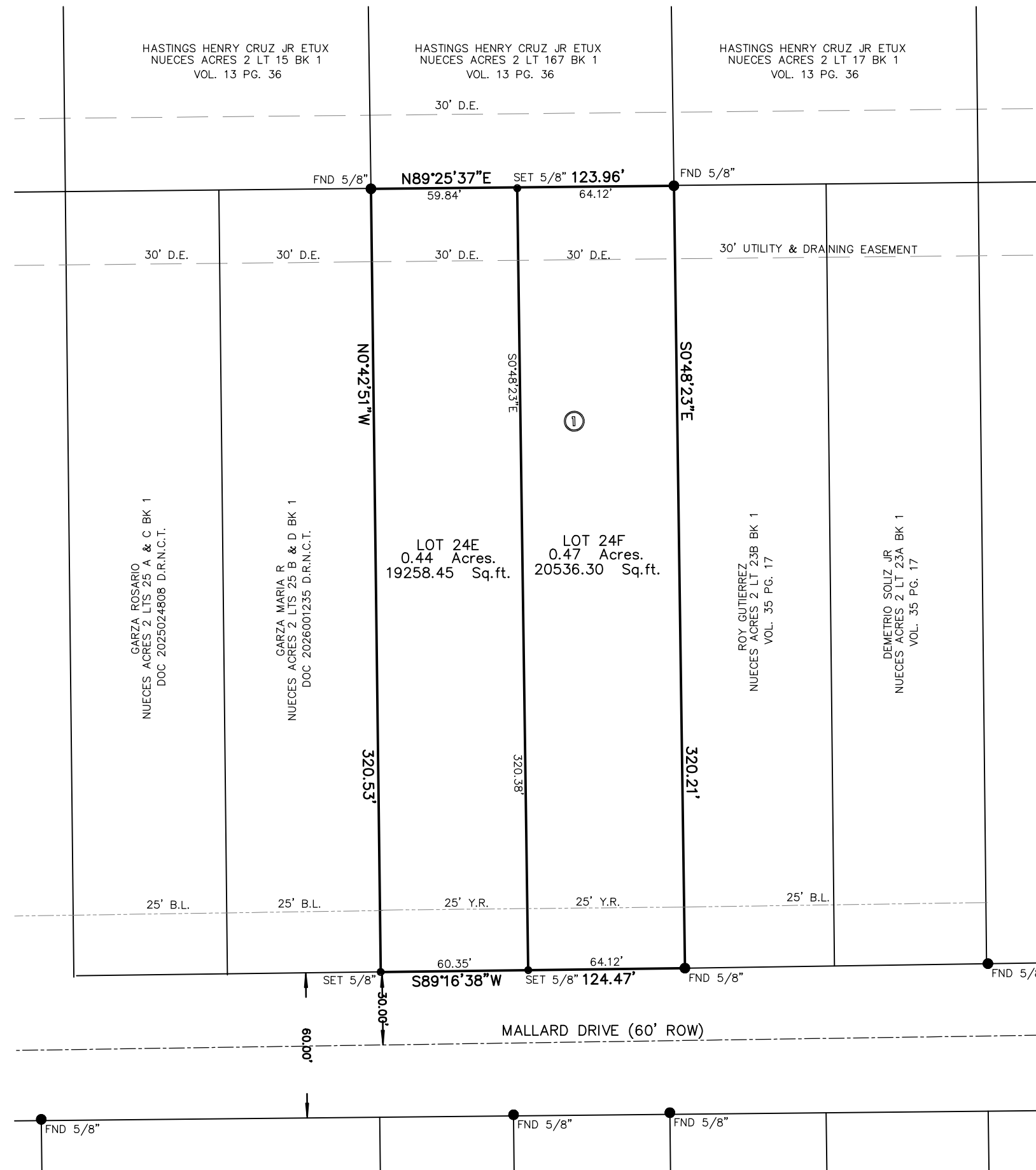

GENERAL NOTES:

- 1) THE TOTAL PLATTED AREA CONTAINS 0.91 ACRES OF LAND.
- 2) THE YARD REQUIREMENT, AS DEPICTED IS A REQUIREMENT OF THE UNIFIED DEVELOPMENT CODE AND IS SUBJECT TO CHANGE AS THE ZONING MAY CHANGE.
- 3) PER FLOOD INSURANCE RATE MAP, MAP INDEX, COMMUNITY-PANEL NUMBER 48355C0280G, MAP REVISED 10/13/2022, THE SUBJECT PROPERTY IS LOCATED IN ZONE X AREAS OF MINIMAL FLOOD HAZARD.
- 4) ALL BEARINGS REFER TO THE TEXAS STATE PLANE COORDINATE SYSTEM OF 1983, TEXAS SOUTH ZONE.
- 5) THE RECEIVING WATER FOR THE STORM WATER RUNOFF FROM THIS PROPERTY IS THE OSO CREEK. THE TCEQ HAS NOT CLASSIFIED THE AQUATIC LIFE USE FOR THE OSO CREEK, BUT IT IS RECOGNIZED AS AN ENVIRONMENTALLY SENSITIVE AREA. THE OSO CREEK FLOWS DIRECTLY INTO THE OSO BAY. THE TCEQ HAS CLASSIFIED THE AQUATIC LIFE USE FOR THE OSO BAY AS "EXCEPTIONAL" AND "OYSTER WATERS" AND CATEGORIZED THE RECEIVING WATER AS "CONTACT RECREATION" USE.
- 6) PROPOSED DRIVEWAY ACCESS TO A PUBLIC CITY STREET SHALL CONFORM TO ACCESS MANAGEMENT STANDARDS OUTLINED IN ARTICLE 7 OF THE UDC (UDC 7.1.7)
- 7) DURING THE DEVELOPMENT OF THE SITE, ANY INCREASE IN STORMWATER RUNOFF FLOW RATES MUST BE MITIGATED IN ACCORDANCE WITH UDC 8.2.8A, 8.2.B, AND ID1 3.05 RESULTING IN NO ADVERSE IMPACT BETWEEN EXISTING CONDITIONS AND PROPOSED CONDITIONS.

STATE OF TEXAS
COUNTY OF NUECES
I, KARA SANDS, CLERK OF THE COUNTY COURT IN AND FOR NUECES COUNTY, TEXAS, DO HEREBY CERTIFY THAT THE FOREGOING INSTRUMENT DATED THE _____ DAY OF _____ 2026, WITH ITS CERTIFICATE OF AUTHENTICATION WAS FILED FOR RECORD IN MY OFFICE THE _____ DAY OF _____ 2026, AT _____ O'CLOCK _____ M. AND DULY RECORDED THE _____ DAY OF _____ 2026, AT _____ O'CLOCK _____ M., IN VOLUME _____, PAGE _____, MAP RECORDS NUECES COUNTY, TEXAS.

KARA SANDS, COUNTY CLERK
NUECES COUNTY, TEXAS
AT _____ O'CLOCK _____ M.
_____, 2026
BY: _____ DEPUTY

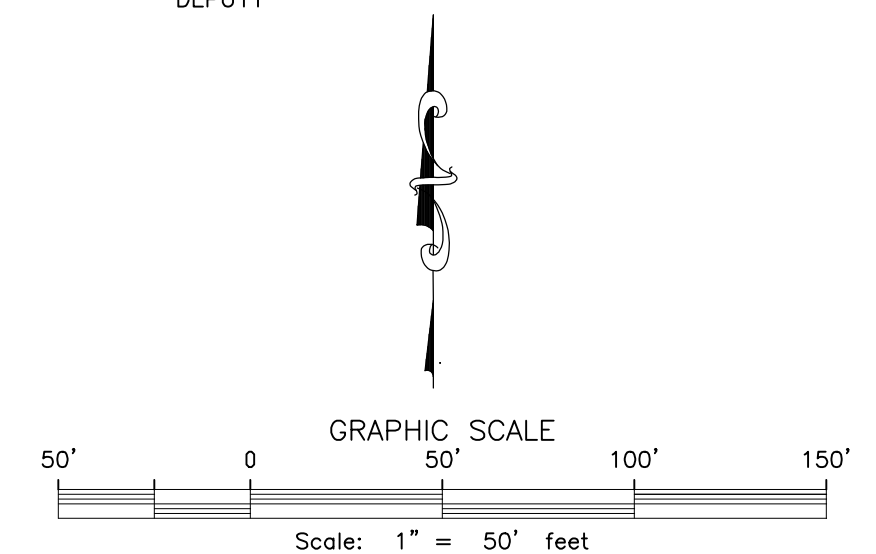

TEXAS GEO TECH
LAND SURVEYING, INC
5525 S. STAPLES ST. SUITE B2
Corpus Christi, TX 78411
(361) 993-0808 Fax (361) 993-2955
JOB # 260502
MAY 27, 2026