

## SERVICE AGREEMENT NO. 3979

### Gate Replacements for Mary Rhodes Pipeline (MRP) Easements

THIS **Gate Replacements for Mary Rhodes Pipeline (MRP) Easements Agreement** ("Agreement") is entered into by and between the City of Corpus Christi, a Texas home-rule municipal corporation ("City") and Beck Brothers, Inc. ("Contractor"), effective upon execution by the City Manager or the City Manager's designee ("City Manager").

WHEREAS, Contractor has bid to provide Gate Replacements for Mary Rhodes Pipeline (MRP) Easements in response to Request for Bid/Proposal No. 3979 ("RFB/RFP"), which RFB/RFP includes the required scope of work and all specifications and which RFB/RFP and the Contractor's bid or proposal response, as applicable, are incorporated by reference in this Agreement as Exhibits 1 and 2, respectively, as if each were fully set out here in its entirety.

NOW, THEREFORE, City and Contractor agree as follows:

**1. Scope.** Contractor will provide Gate Replacements for Mary Rhodes Pipeline (MRP) Easements ("Services") in accordance with the attached Scope of Work, as shown in Attachment A, the content of which is incorporated by reference into this Agreement as if fully set out here in its entirety, and in accordance with Exhibit 2.

**2. Term.**

(A) This Agreement is for one year. The parties may mutually extend the term of this Agreement for up to two additional one-year periods ("Option Period(s)"), provided, the parties do so in writing prior to the expiration of the original term or the then-current Option Period.

(B) At the end of the Term of this Agreement or the final Option Period, the Agreement may, at the request of the City prior to expiration of the Term or final Option Period, continue on a month-to-month basis for up to six months with compensation set based on the amount listed in Attachment B for the Term or the final Option Period. The Contractor may opt out of this continuing term by providing notice to the City at least 30 days prior to the expiration of the Term or final Option Period. During the month-to-month term, either Party may terminate the Agreement upon 30 days' written notice to the other Party.

- 3. Compensation and Payment.** This Agreement is for an amount not to exceed \$76,439.90, subject to approved extensions and changes. Payment will be made for Services performed and accepted by the City within 30 days of acceptance, subject to receipt of an acceptable invoice. All pricing must be in accordance with the attached Bid/Pricing Schedule, as shown in Attachment B, the content of which is incorporated by reference into this Agreement as if fully set out here in its entirety. Any amount not expended during the initial term or any option period may, at the City's discretion, be allocated for use in the next Option Period.

Invoices must be mailed to the following address with a copy provided to the Contract Administrator:

City of Corpus Christi  
Attn: Accounts Payable  
P.O. Box 9277  
Corpus Christi, Texas 78469-9277

- 4. Contract Administrator.** The Contract Administrator designated by the City is responsible for approval of all phases of performance and operations under this Agreement, including deductions for non-performance and authorizations for payment. The City's Contract Administrator for this Agreement is as follows:

Name: Diana Zeruche-Garza  
Department: Utilities Department  
Phone: (361) 826-1627  
Email: DianaZ@cctexas.com

**5. Insurance; Bonds.**

(A) Before performance can begin under this Agreement, the Contractor must deliver a certificate of insurance ("COI"), as proof of the required insurance coverages, to the City's Risk Manager and the Contract Administrator. Additionally, the COI must state that the City will be given at least 30 days' advance written notice of cancellation, material change in coverage, or intent not to renew any of the policies. The City must be named as an additional insured. The City Attorney must be given copies of all insurance policies within 10 days of the City Manager's written request. Insurance requirements are as stated in Attachment C, the content of which is incorporated by reference into this Agreement as if fully set out here in its entirety.

(B) In the event that a payment bond, a performance bond, or both, are required of the Contractor to be provided to the City under this Agreement before performance can commence, the terms, conditions, and amounts required in the bonds and appropriate surety information are as included in the RFB/RFP or as

may be added to Attachment C, and such content is incorporated here in this Agreement by reference as if each bond's terms, conditions, and amounts were fully set out here in its entirety.

**6. Purchase Release Order.** For multiple-release purchases of Services to be provided by the Contractor over a period of time, the City will exercise its right to specify time, place and quantity of Services to be delivered in the following manner: any City department or division may send to Contractor a purchase release order signed by an authorized agent of the department or division. The purchase release order must refer to this Agreement, and Services will not be rendered until the Contractor receives the signed purchase release order.

**7. Inspection and Acceptance.** City may inspect all Services and products supplied before acceptance. Any Services or products that are provided but not accepted by the City must be corrected or re-worked immediately at no charge to the City. If immediate correction or re-working at no charge cannot be made by the Contractor, a replacement service may be procured by the City on the open market and any costs incurred, including additional costs over the item's bid/proposal price, must be paid by the Contractor within 30 days of receipt of City's invoice.

**8. Warranty.**

(A) The Contractor warrants that all products supplied under this Agreement are new, quality items that are free from defects, fit for their intended purpose, and of good material and workmanship. The Contractor warrants that it has clear title to the products and that the products are free of liens or encumbrances.

(B) In addition, the products purchased under this Agreement shall be warranted by the Contractor or, if indicated in Attachment D by the manufacturer, for the period stated in Attachment D. Attachment D is attached to this Agreement and is incorporated by reference into this Agreement as if fully set out here in its entirety.

(C) Contractor warrants that all Services will be performed in accordance with the standard of care used by similarly situated contractors performing similar services.

**9. Quality/Quantity Adjustments.** Any Service quantities indicated on the Bid/Pricing Schedule are estimates only and do not obligate the City to order or accept more than the City's actual requirements nor do the estimates restrict the City from ordering less than its actual needs during the term of the Agreement and including any Option Period. Substitutions and deviations from the City's product requirements or specifications are prohibited without the prior written approval of the Contract Administrator.

- 10. Non-Appropriation.** The continuation of this Agreement after the close of any fiscal year of the City, which fiscal year ends on September 30<sup>th</sup> annually, is subject to appropriations and budget approval specifically covering this Agreement as an expenditure in said budget, and it is within the sole discretion of the City's City Council to determine whether or not to fund this Agreement. The City does not represent that this budget item will be adopted, as said determination is within the City Council's sole discretion when adopting each budget.
- 11. Independent Contractor.** Contractor will perform the work required by this Agreement as an independent contractor and will furnish such Services in its own manner and method, and under no circumstances or conditions will any agent, servant or employee of the Contractor be considered an employee of the City.
- 12. Subcontractors.** In performing the Services, the Contractor will not enter into subcontracts or utilize the services of subcontractors.
- 13. Amendments.** This Agreement may be amended or modified only in writing executed by authorized representatives of both parties.
- 14. Waiver.** No waiver by either party of any breach of any term or condition of this Agreement waives any subsequent breach of the same.
- 15. Taxes.** The Contractor covenants to pay payroll taxes, Medicare taxes, FICA taxes, unemployment taxes and all other applicable taxes. Upon request, the City Manager shall be provided proof of payment of these taxes within 15 days of such request.
- 16. Notice.** Any notice required under this Agreement must be given by fax, hand delivery, or certified mail, postage prepaid, and is deemed received on the day faxed or hand-delivered or on the third day after postmark if sent by certified mail. Notice must be sent as follows:

**IF TO CITY:**

City of Corpus Christi  
Attn: Diana Zertuche-Garza  
Title: Contracts/Funds Administrator  
Address: 2726 Holly Road, Corpus Christi, Texas 78415  
Phone: (361) 826-1627  
Fax: (361) 826-4495

**IF TO CONTRACTOR:**

Beck Brothers, Inc.  
Attn: Austin McCray  
Title: Project Supervisor  
Address: P.O. Box 712 Beeville, Texas 78104  
Phone: (361) 358-2957

Fax: N/A

**17. CONTRACTOR SHALL FULLY INDEMNIFY, HOLD HARMLESS AND DEFEND THE CITY OF CORPUS CHRISTI AND ITS OFFICERS, EMPLOYEES AND AGENTS (“INDEMNITEES”) FROM AND AGAINST ANY AND ALL LIABILITY, LOSS, CLAIMS, DEMANDS, SUITS, AND CAUSES OF ACTION OF WHATEVER NATURE, CHARACTER, OR DESCRIPTION ON ACCOUNT OF PERSONAL INJURIES, PROPERTY LOSS, OR DAMAGE, OR ANY OTHER KIND OF INJURY, LOSS, OR DAMAGE, INCLUDING ALL EXPENSES OF LITIGATION, COURT COSTS, ATTORNEYS’ FEES AND EXPERT WITNESS FEES, WHICH ARISE OR ARE CLAIMED TO ARISE OUT OF OR IN CONNECTION WITH A BREACH OF THIS AGREEMENT OR THE PERFORMANCE OF THIS AGREEMENT BY THE CONTRACTOR OR RESULTS FROM THE NEGLIGENT ACT, OMISSION, MISCONDUCT, OR FAULT OF THE CONTRACTOR OR ITS EMPLOYEES OR AGENTS. CONTRACTOR MUST, AT ITS OWN EXPENSE, INVESTIGATE ALL CLAIMS AND DEMANDS, ATTEND TO THEIR SETTLEMENT OR OTHER DISPOSITION, DEFEND ALL ACTIONS BASED THEREON WITH COUNSEL SATISFACTORY TO THE CITY ATTORNEY, AND PAY ALL CHARGES OF ATTORNEYS AND ALL OTHER COSTS AND EXPENSES OF ANY KIND ARISING OR RESULTING FROM ANY SAID LIABILITY, DAMAGE, LOSS, CLAIMS, DEMANDS, SUITS, OR ACTIONS. THE INDEMNIFICATION OBLIGATIONS OF CONTRACTOR UNDER THIS SECTION SHALL SURVIVE THE EXPIRATION OR EARLIER TERMINATION OF THIS AGREEMENT.**

**18. Termination.**

(A) The City may terminate this Agreement for Contractor’s failure to comply with any of the terms of this Agreement. The City must give the Contractor written notice of the breach and set out a reasonable opportunity to cure. If the Contractor has not cured within the cure period, the City may terminate this Agreement immediately thereafter.

(B) Alternatively, the City may terminate this Agreement for convenience upon 30 days advance written notice to the Contractor. The City may also terminate this Agreement upon 24 hours written notice to the Contractor for failure to pay or provide proof of payment of taxes as set out in this Agreement.

**19. Owner’s Manual and Preventative Maintenance.** Contractor agrees to provide a copy of the owner’s manual and/or preventative maintenance guidelines or instructions if available for any equipment purchased by the City pursuant to this Agreement. Contractor must provide such documentation upon delivery of such equipment and prior to receipt of the final payment by the City.

- 20. Limitation of Liability.** The City's maximum liability under this Agreement is limited to the total amount of compensation listed in Section 3 of this Agreement. In no event shall the City be liable for incidental, consequential or special damages.
- 21. Assignment.** No assignment of this Agreement by the Contractor, or of any right or interest contained herein, is effective unless the City Manager first gives written consent to such assignment. The performance of this Agreement by the Contractor is of the essence of this Agreement, and the City Manager's right to withhold consent to such assignment is within the sole discretion of the City Manager on any ground whatsoever.
- 22. Severability.** Each provision of this Agreement is considered to be severable and, if, for any reason, any provision or part of this Agreement is determined to be invalid and contrary to applicable law, such invalidity shall not impair the operation of nor affect those portions of this Agreement that are valid, but this Agreement shall be construed and enforced in all respects as if the invalid or unenforceable provision or part had been omitted.
- 23. Order of Precedence.** In the event of any conflicts or inconsistencies between this Agreement, its attachments, and exhibits, such conflicts and inconsistencies will be resolved by reference to the documents in the following order of priority:
- A. this Agreement (excluding attachments and exhibits);
  - B. its attachments;
  - C. the bid solicitation document including any addenda (Exhibit 1); then,
  - D. the Contractor's bid response (Exhibit 2).
- 24. Certificate of Interested Parties.** Contractor agrees to comply with Texas Government Code Section 2252.908, as it may be amended, and to complete Form 1295 "Certificate of Interested Parties" as part of this Agreement if required by said statute.
- 25. Governing Law.** Contractor agrees to comply with all federal, Texas, and City laws in the performance of this Agreement. The applicable law for any legal disputes arising out of this Agreement is the law of the State of Texas, and such form and venue for such disputes is the appropriate district, county, or justice court in and for Nueces County, Texas.
- 26. Public Information Act Requirements.** This paragraph applies only to agreements that have a stated expenditure of at least \$1,000,000 or that result in the expenditure of at least \$1,000,000 by the City. The requirements of Subchapter J, Chapter 552, Government Code, may apply to this contract and the Contractor agrees that the contract can be terminated if the Contractor knowingly or intentionally fails to comply with a requirement of that subchapter.

**27. Entire Agreement.** This Agreement constitutes the entire agreement between the parties concerning the subject matter of this Agreement and supersedes all prior negotiations, arrangements, agreements and understandings, either oral or written, between the parties.

**CONTRACTOR**

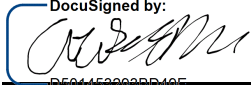
Signature:  \_\_\_\_\_  
Printed Name: Austin McCray \_\_\_\_\_  
Title: Project Supervisor \_\_\_\_\_  
Date: 1/28/2022 \_\_\_\_\_

**CITY OF CORPUS CHRISTI**

\_\_\_\_\_  
Josh Chronley  
Assistant Director, Contracts and Procurement  
  
Date: \_\_\_\_\_

- Attached and Incorporated by Reference:**  
Attachment A: Scope of Work  
Attachment B: Bid/Pricing Schedule  
Attachment C: Insurance and Bond Requirements  
Attachment D: Warranty Requirements

- Incorporated by Reference Only:**  
Exhibit 1: RFB/RFP No. 3979  
Exhibit 2: Contractor's Bid/Proposal Response



## **Attachment A - Scope of Work**

### **1.1 General Requirements/Background Information**

- A. The Contractor shall provide services for gate replacements from Lake Texana to Corpus Christi on the Mary Rhodes Pipeline (MRP) easements as outlined in this Scope of Work. There are one hundred (100) miles of pipeline easements where gates are installed, please see Exhibit 4.
- B. The gate replacements for the Mary Rhodes Pipeline easements are undertaken in accordance with the Water Department's maintenance operations of the Water Supply System. All areas are in Nueces County, San Patricio County, Refugio County, Victoria County and Jackson County.
- C. The Contractor shall be responsible for labor, supervision, equipment and transportation necessary for these services.
- D. The Contractor shall have enough resources and personnel to perform the work as specified in this Scope of Work.
- E. A City of Corpus Christi technician will accompany the Contractor to the pre-designated property for the duration of the repair.

### **1.2 Scope of Work**

- A. The Contractor shall replace gates according to the details in Exhibit 1, Exhibit 2 and Exhibit 3, which includes travel charges and labor.
- B. The Contractor shall install Ranger Gates from Yoakum, Texas or an approved equal by the Contract Administrator; all hardware must be galvanized and the following materials must be used for each gate:
  - 1. The Contractor shall use 5/16<sup>th</sup> grade 30 galvanized chain cut at the correct length for locking the gates;
  - 2. The Contractor shall use ¾" x 16" long galvanized hinges;
  - 3. The Contractor shall use 1 – 5/8" 6-tube galvanized 16-gauge gate;
  - 4. All augured holes shall be 16" for all the 10"x10' poles;
  - 5. The Contractor shall use Exhibit 1 and Exhibit 2 for all specifications;
  - 6. One gate replaced each year will be a double wide gate. (Please see Exhibit 3). Each gate is 10ft wide for a total width of 20ft.
- C. The Contractor shall construct the replacement gate over the center of the Mary Rhodes Pipeline which will be at the same location of the gate being replaced, unless directed to a different location by City staff.
- D. The Contractor shall make gate adjustments in order for gates to open and close correctly without binding.

- E. The Contractor shall remove gates, posts and other materials not claimed by the City at each location and dispose at the proper location/facility.
- F. The Contractor shall provide gate replacements on an as needed basis.

### **1.3 Work Site Locations and Safety**

- A. The Contractor shall replace gates along the Mary Rhodes Pipeline easements from Lake Texana in Edna, Texas to the Nueces River in Corpus Christi, Texas, please see Exhibit 4.
- B. The Contractor shall start each gate replacement location within three working days after notification. Line location should be called in on first day in order to start work within the three-day time frame.
- C. The Contractor must be able to respond to call out for gate failure within five (5) days for the duration of this agreement.
- D. The Contractor shall be on site no later than 9:00 a.m. each day; no weekend work unless approved by Contract Administrator.
- E. The Contractor is responsible for calling in line location and responding before work is performed.
- F. Contractor shall use proper equipment and safety protocols to ensure the safety of all personnel working at the site.
- G. The Contractor shall carry their own water supply and fire extinguishers.
- H. The Contractor shall not smoke on any of the properties.

### **1.4 Work Site Completion/Inspection**

- A. The Contractor shall complete each site in two days to allow concrete to dry before having gate and spread out any excess dirt before leaving the job site.
- B. The Contractor will submit invoice(s) to be paid after gate is completed and City staff has inspected the completed gate.

### **1.5 Invoicing**

- A. The Contractor shall submit an itemized invoice for each shipment for payment, which shall include the following:
  - 1. Supply Agreement No. and Purchase Order No.
  - 2. Ship to: Location Name and Address
  - 3. Tank Car Number
  - 4. Ordered by: Supply Name
  - 5. Product Description
  - 6. Quantity, Unit Price and Total Price

### **1.6 Warranty**

- A. The work and materials provided shall be warrantied for one year after installation of each gate.

### Exhibit 1

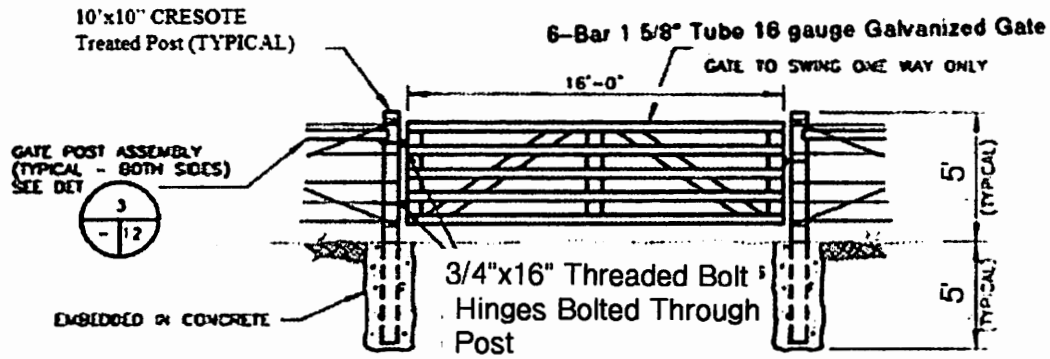

- NOTE:
1. POSITION GATE IN FENCE SO THAT THE CENTER OF THE GATE IS DIRECTLY ABOVE THE CENTERLINE OF PROPOSED WATERLINE OR AS CLOSE TO THE CENTER AS POSSIBLE IF GATE TO BE INSTALLED AT FENCE CORNER.
  2. SEE SPECIFICATIONS SECTION 02600 FOR LOCK REQUIREMENTS.

2 TYPICAL GATE INSTALLATION

- 12 SCALE: NONE

Exhibit 2

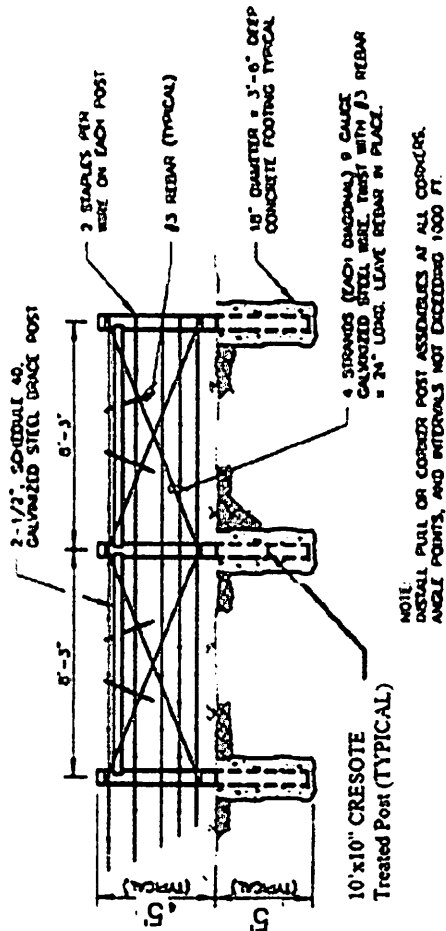

3  
-12

GATE CORNER OR PULL POST ASSEMBLY

SCALE: NONE

# Exhibit 3

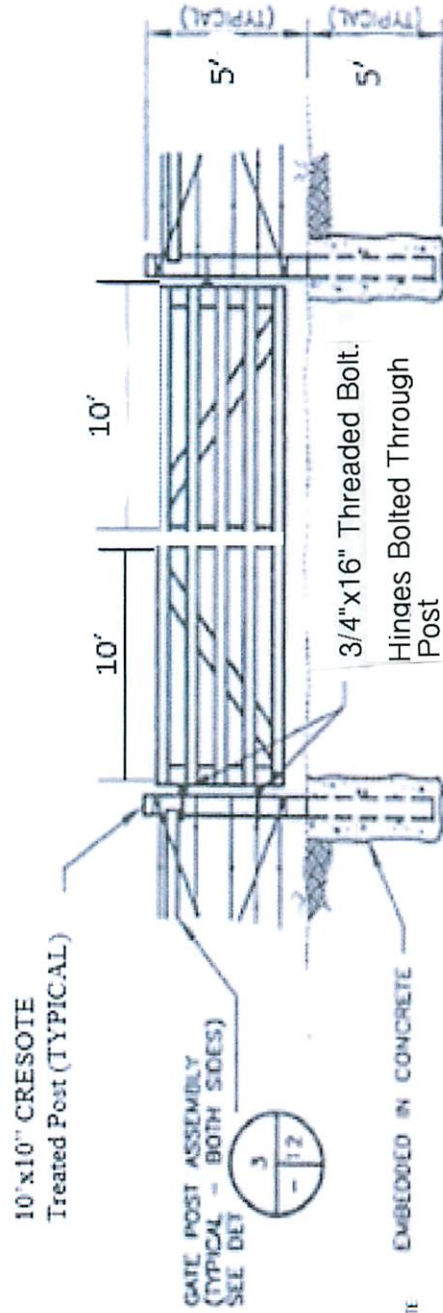

NOTE

1. POSITION GATE IN FENCE SO THAT THE CENTER OF THE GATE IS DIRECTLY ABOVE THE CENTERLINE

OF PROPOSED WATERTUNE OR AS CLOSE TO THE

CENTER AS POSSIBLE IF GATE TO BE INSTALLED AT FENCE CORNER

2. SEE SPECIFICATION SECTION 02560 FOR LOCK REQUIREMENT

3. 2 SEPARATE GATES AT 30' LENGTHS



**TYPICAL GATE INSTALLATION**

SCALE: NONE

## **Exhibit 4 - Map**

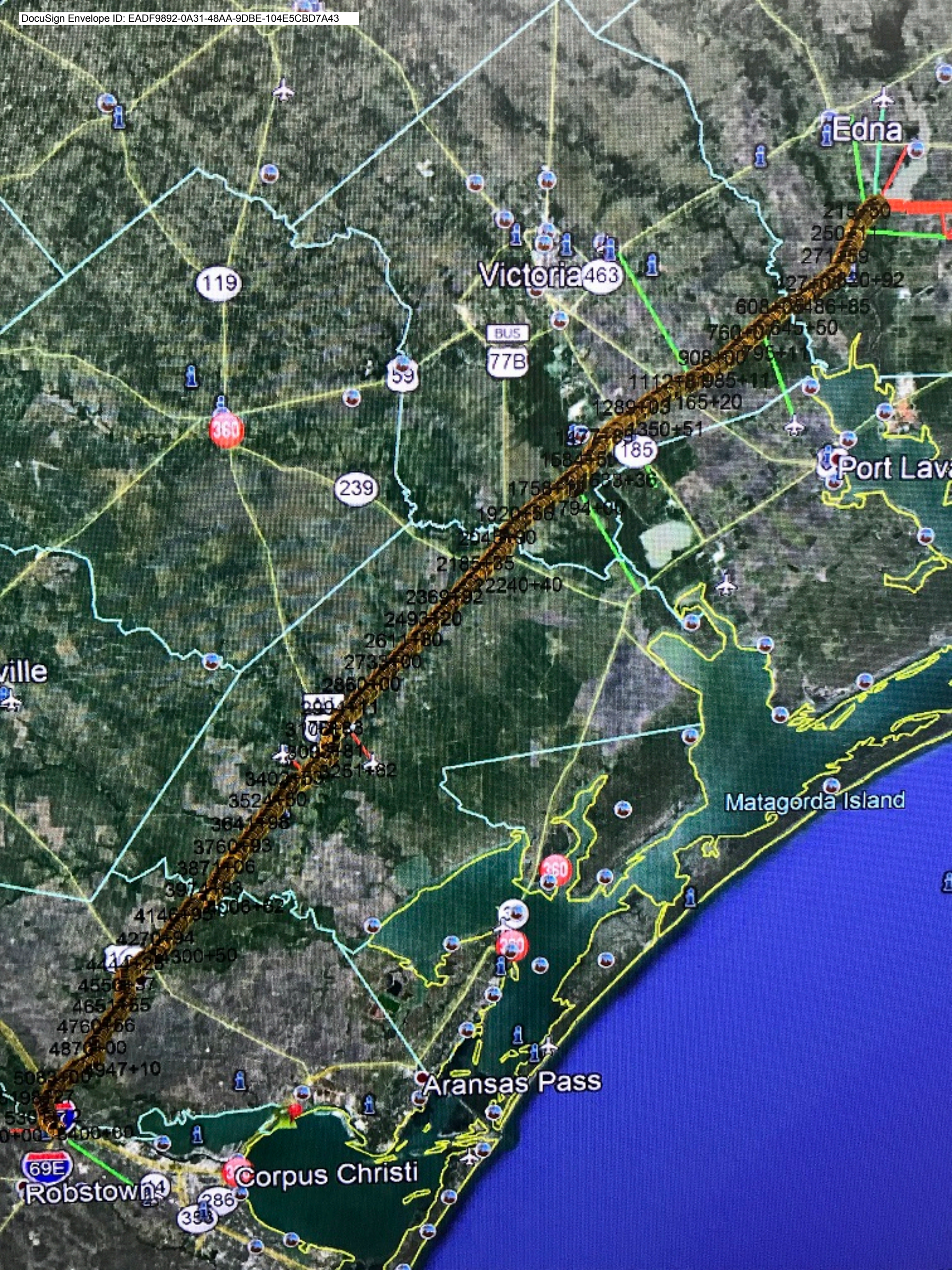

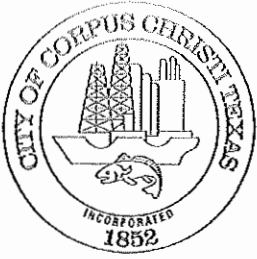
**Attachment B - Bid/Pricing Schedule**

**CITY OF CORPUS CHRISTI  
CONTRACTS AND PROCUREMENT  
BID FORM**

RFB No. 3979

Gate Replacements for (MRP) Easements

Date: 12-21-21

PAGE 1 OF 2

Bidder: Beck Bros IncAuthorized  
Signature:

1. Refer to "Instructions to Bidders" and Contract Terms and Conditions before completing bid.
2. Quote your best price for each item.
3. In submitting this bid, Bidder certifies that:
  - a. the prices in this bid have been arrived at independently, without consultation, communication, or agreement with any other Bidder or competitor, for the purpose of restricting competition with regard to prices.
  - b. Bidder is an Equal Opportunity Employer, and the Disclosure of Interest information on file with City's Contracts and Procurement office, pursuant to the Code of Ordinances, is current and true.
  - c. Bidder is current with all taxes due and company is in good standing with all applicable governmental agencies.
  - d. Bidder acknowledges receipt and review of all addenda for this RFB.

Item	Description	UNIT	Annual Qty	Unit Price	Total Price
1.	Remove and replace typical gate assembly per detail (see Exhibits 1 & 2); (include materials, parts, equipment, labor & trip charge)	EA	12	\$ 5,857. <sup>00</sup>	\$ 70,294. <sup>80</sup>
2.	Remove and replace doublewide gate assembly per detail (see Exhibit 3); (include materials, parts, equipment, labor & trip charge)	EA	1	\$ 6,145. <sup>10</sup>	\$ 6,145. <sup>10</sup>
Total					\$ 76,439. <sup>90</sup>



1 <sup>st</sup> -Year Extension Option					
Item	Description	UNIT	Annual Qty	Unit Price	Total Price
1.	Remove and replace typical gate assembly per detail (see Exhibits 1 & 2); (include materials, parts, equipment, labor & trip charge)	EA	12	\$ 5,857.90	\$ 70,294.80
2.	Remove and replace doublewide gate assembly per detail (see Exhibit 3); (include materials, parts, equipment, labor & trip charge)	EA	1	\$ 6,145.10	\$ 6,145.10
Total					\$ 76,439.90

2 <sup>nd</sup> -Year Extension Option					
Item	Description	UNIT	Annual Qty	Unit Price	Total Price
1.	Remove and replace typical gate assembly per detail (see Exhibits 1 & 2); (include materials, parts, equipment, labor & trip charge)	EA	12	\$ 5,857.90	\$ 70,294.80
2.	Remove and replace doublewide gate assembly per detail (see Exhibit 3); (include materials, parts, equipment, labor & trip charge)	EA	1	\$ 6,145.10	\$ 6,145.10
Total					\$ 76,439.90
Grand Total					\$ 229,319.70

## Attachment C - Insurance Requirements

### CONTRACTOR'S LIABILITY INSURANCE

1. Contractor must not commence work under this agreement until all insurance required herein has been obtained and approved by the City's. Contractor must not allow any subcontractor Agency to commence work until all similar insurance required of the subcontractor Agency has been so obtained.
2. Contractor must furnish to the City's Risk Manager and Contract Administrator, one (1) copy of Certificates of Insurance (COI) with applicable policy endorsements showing the following minimum coverage by an insurance company(s) acceptable to the City's Risk Manager. The City must be listed as an additional insured for the General Liability and Auto Liability policies **by endorsement**, and a waiver of subrogation is required on all applicable policies. **Endorsements** must be provided with COI. Project name and or number must be listed in Description Box of COI.

TYPE OF INSURANCE	MINIMUM INSURANCE COVERAGE
Commercial General Liability including: 1. Commercial Broad Form 2. Premises – Operations 3. Products/ Completed Operations 4. Contractual Liability 5. Independent Contractors 6. Personal Injury- Advertising Injury	\$1,000,000 Per Occurrence
AUTOMOBILE LIABILITY (including) 1. Owned 2. Hired & Non-owned 3. Rented & Leased	\$ 500,000 Combined Single Limit
WORKERS' COMPENSATION  Employer's Liability	Statutory  \$500,000 / \$500,000 / \$500,000

3. In the event of accidents of any kind related to this project, Consultant must furnish the Risk Manager with copies of all reports of such accidents within 10 days of the accident.

### Additional Requirements –

1. Applicable for paid employees, Contractor must obtain workers'

compensation coverage through a licensed insurance company. The coverage must be written on a policy and endorsements approved by the Texas Department of Insurance. The workers' compensation coverage provided must be in an amount sufficient to assure that all workers' compensation obligations incurred by the Contractor will be promptly met. An All-States endorsement shall be required if consultant is not domiciled in the State of Texas.

2. Contractor shall obtain and maintain in full force and effect for the duration of this Contract, and any extension hereof, at Contractor's sole expense, insurance coverage written on an occurrence basis, by companies authorized and admitted to do business in the State of Texas and with an A.M. Best's rating of no less than A- VII.
3. Contractor shall be required to submit replacement Certificate of Insurance to City at the address provided below within 10 days of any change made by the Contractor or as requested by the City. Contractor shall pay any costs incurred resulting from said changes. All notices under this Article shall be given to City at the following address:

City of Corpus Christi  
Attn: Risk Management  
P.O. Box 9277  
Corpus Christi, TX 78469-9277

**4. Contractor agrees that with respect to the above required insurance, all insurance policies are to contain or be endorsed to contain the following required provisions:**

- List the City and its officers, officials, employees, and volunteers, as additional insureds by endorsement with regard to operations, completed operations and activities of or on behalf of the named insured performed under contract with the City, with the exception of the workers' compensation policy.
- Provide for an endorsement that the "other insurance" clause shall not apply to the City of Corpus Christi where the City is an additional insured shown on the policy;
- Workers' compensation and employers' liability policies will provide a waiver of subrogation in favor of the City; and
- Provide 30 calendar days advance written notice directly to City of any cancellation, non-renewal, material change or termination in coverage and

not less than ten calendar days advance written notice for nonpayment of premium.

5. Within five calendar days of a cancellation, non-renewal, material change or termination of coverage, Contractor shall provide a replacement Certificate of Insurance and applicable endorsements to City. City shall have the option to suspend Contractor's performance should there be a lapse in coverage at any time during this contract. Failure to provide and to maintain the required insurance shall constitute a material breach of this contract.
6. In addition to any other remedies the City may have upon Contractor's failure to provide and maintain any insurance or policy endorsements to the extent and within the time herein required, the City shall have the right to order Contractor to stop work hereunder, and/or withhold any payment(s) which become due to Consultant hereunder until Contractor demonstrates compliance with the requirements hereof.
7. Nothing herein contained shall be construed as limiting in any way the extent to which Contractor may be held responsible for payments of damages to persons or property resulting from Contractor's or its subcontractor's performance of the work covered under this contract.
8. It is agreed that Contractor's insurance shall be deemed primary and non-contributory with respect to any insurance or self-insurance carried by the City of Corpus Christi for liability arising out of operations under this contract.
9. It is understood and agreed that the insurance required is in addition to and separate from any other obligation contained in this agreement.

**Bond Requirements:**

No bond requirements, therefore, Agreement Section 5 Insurance; Bond subsection 5(B), is hereby void.

2021 Insurance Requirements  
Ins. Req. Exhibit **4-B**  
Contracts for General Services – Services Performed Onsite  
05/10/2021 Risk Management – Legal Dept.

## **Attachment D - Warranty Requirements**

The work and materials provided shall be warranted for one year after installation of each gate.